



No. N-11019/11/2019-HFA-V-UD (FTS-9061587)
Government of India
Ministry of Housing and Urban Affairs

Room No. 3, Technical Cell, Gate No. 7,
Nirman Bhawan, New Delhi
Dated 05th July, 2019

LETTER OF INVITATION

Dear Sir,

MINISTRY OF HOUSING AND URBAN AFFAIRS, GOVERNMENT OF INDIA (hereinafter called "MoHUA") has initiated the Global Housing Technology Challenge- India (GHTC-India) which aims to identify and mainstream a basket of innovative construction technologies from across the globe for affordable housing that are sustainable, green and disaster-resilient. In this regard, MoHUA is issuing Request for Proposal (RFP) for construction of Light House Projects (LHPs) at six sites, selected through a challenge process under GHTC-India.

2. MoHUA hereby invites the technical and financial proposals for construction of LHPs at six locations under GHTC-India using location specific exclusive alternate technologies which were shortlisted during the process of Construction Technology India-2019 Expo-cum-Conference.

3. The RFP includes the following sections:

Part-I: General Information

Part-II: Technical Bid

Part-III: Financial Bid

Section A – General Conditions of work and planning and designing

Section B – Conditions and specifications of works

Section C – Architectural Norms, Schedule of finishes and general specifications

Section D – Schedule of Stage Payments

Section E – Schedule of Quantities

Section F – Technical Specifications for shortlisted proven technologies

Section G – Drawing of EWS Housing for six Light House Project Sites

4. In case any holiday is declared by the Government on the day of opening, the tenders will be opened on the next working day at the same time. This RFP is being issued with no financial commitment and MoHUA reserves the right to change or vary any part thereof at any stage. MoHUA also reserves the right to withdraw the RFP, should it be so necessary at any stage.

5. It is not permissible to transfer this invitation to any other agency.

(B.K. Mandal)

Under Secretary to the Govt. of India

Tel: +91-11-23063285



**REQUEST FOR PROPOSAL (RFP) FOR
ENGINEERING PROCUREMENT CONSTRUCTION MODE FOR THE
DEVELOPMENT AND CONSTRUCTION OF EWS HOUSES UNDER LIGHT HOUSE
PROJECTS IN SIX STATES AT SELECTED SITE UNDER GLOBAL HOUSING
TECHNOLOGY CHALLENGE-INDIA (GHTC-INDIA)**

Issued on:

Reference No. N-11019/11/2019-HFA-V-UD/ Computer No: 9061587

**Organization: Ministry of Housing and Urban Affairs (MoHUA),
Government of India.**

Represented by:

**Joint Secretary and Mission Director (HFA), MoHUA, Room No. 116 G,
Nirman Bhawan, Maulana Azad Road, New Delhi -110011**

INDEX

Sl. No	Description	Page No
Part-I: General Information		
1	Disclaimer	4-5
2	Information & instructions for Participating Agency for e-Bidding	6-26
3	ANNEXURE-I: Instructions for Online Bid Submission	27-29
4	ANNEXURE-A: Recommended Locations for Broad categories of Technologies	30-31
Part-II: Technical Bid		
1	Glossary	32
2	Section-I: Brief of work	33-34
3	Section-II: Information and Guide-lines for Participating Agency	35-38
4	ANNEXURE-II: Criteria for Evaluation of the performance of participating agency for Pre-Eligibility	39-40
5	Section-III: Templates of forms	41-50
6	ANNEXURE-III: Integrity Pact	51-57
Part-III: Financial Bid		
1	Contract Conditions	58-98
2	ANNEXURE-IV: MEMORANDUM	99-101
3	ANNEXURE-V: Performa for JVA	102-104
4	ANNEXURE-VI: Establishing Site Laboratory	105
5	ANNEXURE-VII: Requirements of Plant and Equipment	106
6	ANNEXURE-VIII: Minimum Requirement of Technical Representative at Site	107-108
Section- A: General Conditions of Work & Planning and Designing		
1	Use of New Technology	109-110
2	Scope of Work	111-113
3	General Condition for Planning & Design	114-117
4	Project Management	118
Section-B: Conditions & Specifications of works		
1	General Conditions for Works	119-124
2	General Specifications of Civil Works	125
3	General Specifications of E&M works	126-132
4	List of Approved makes	133-138
5	ANNEXURE-IX: Guarantee bond for waterproofing works	139-140
Section-C: Architectural Norms, Schedule of Finishes & General Specifications		
1	Norms and Amenities for Houses	141-143
2	Schedule of Specification for houses	144-147
3	Details of Services and Development works	148-156
Section-D: Schedule of Stage Payments		
1	Payment - Schedule	157-158
Section-E: Schedule of Quantities		

1	Schedule of Quantities	159-164
Section-F: Technical Specifications for Shortlisted Proven Technologies		
1	Technical Specifications for Shortlisted Proven Technologies	165-201
Section-G: Drawings of EWS Housing for 6 Light House Project Sites		
1	Location Map	202-751
2	Total Station Survey Map	
3	Soil Testing Report	
4	Layout Plan	
5	Unit Plan	
6	Floor Plans	
7	Physical Infrastructure Drawings	
8	Social Infrastructure Building Drawings	

Certified that this bid-document contains 751 pages

Part-I: General Information

DISCLAIMER

The information contained in this Request for Proposal document (the “RFP”) or subsequently provided to Participating Agency(s), whether verbally or in documentary or any other form by or on behalf of the Ministry of Housing and Urban Affairs (MoHUA), is provided to Participating Agency(s) on the terms and conditions set out in this RFP and such other terms and conditions subject to which such information is provided. The purpose of this RFP is to provide interested parties with information that may be useful to them in making their Technical and financial bids pursuant to this RFP.

This RFP includes statements, which reflect various assumptions and assessments arrived at by the MoHUA in relation to the Project. Such assumptions, assessments and statements do not purport to contain all the information that each Participating Agency may require in respect of technical specifications, drawings, layouts, soil investigation report, TSS etc. The assumptions, assessments, statements and information contained in the RFP Documents, may not be complete, accurate, adequate or correct in respect of above. Each participating agency should therefore, conduct its own investigations and analysis and should check the accuracy, adequacy, correctness, reliability and completeness of the assumptions, assessments, statements and information contained in this RFP and obtain independent advice from appropriate sources.

Information provided in this RFP to the participating agencies is on a wide range of matters, some of which may depend upon interpretation of law. The information given is not intended to be an exhaustive account of statutory requirements and should not be regarded as a complete or authoritative statement of law. Ministry of Housing and Urban Affairs accepts no responsibility for the accuracy or otherwise for any interpretation or opinion on law expressed herein.

The Ministry of Housing and Urban Affairs make no representation or warranty and shall have no liability to any person, including any Applicant or Participating Agency under any law, statute, rules or regulations or tort, principles of restitution or unjust enrichment or otherwise for any loss, damages, cost or expense which may arise from or be incurred or suffered on account of anything contained in this RFP or otherwise, including the accuracy, adequacy, correctness, completeness or reliability of the RFP and any assessment, assumption, statement or information contained therein or deemed to form part of this RFP or arising in any way for participation in this BID Stage.

The Ministry of Housing and Urban Affairs also accepts no liability of any nature whether resulting from negligence or otherwise howsoever caused arising from reliance of any Participating Agency upon the statements contained in this RFP. The Ministry of Housing and Urban Affairs may in its absolute discretion, but without being under any obligation to do so, update,

amend or supplement the information, assessment or assumptions contained in this RFP.

The issue of this RFP does not imply that the Ministry of Housing and Urban Affairs is bound to select a Participating Agency or to appoint the Participating Agency or Participating agency, as the case may be, for the Project and the Ministry of Housing and Urban Affairs reserves the right to reject all or any of the Participating Agency or bids without assigning any reason whatsoever.

The Participating Agency shall bear all its costs associated with or relating to the preparation and submission of its bid including but not limited to preparation, copying, postage, delivery fees, expenses associated with any demonstrations or presentations which may be required by the MoHUA or any other costs incurred in connection with or relating to its BID. All such costs and expenses will remain with the Participating Agency and the Ministry of Housing and Urban Affairs shall not be liable in any manner whatsoever for the same or for any other costs or other expenses incurred by a Participating Agency in preparation for submission of the BIDs, regardless of the conduct or outcome of the Bidding Process.

Information & instructions for Participating Agency for e-Bidding

REQUEST FOR PROPOSAL (RFP)

1.0 ABOUT GHTC-INDIA AND LIGHT HOUSE PROJECTS

Ministry of Housing and Urban Affairs (MoHUA), Government of India has been implementing Pradhan Mantri Awas Yojana-Urban (PMAY-U) Mission to provide all weather pucca houses to eligible beneficiaries by the year 2022. In order to address housing shortage in a time-bound manner, the conventional system of housing construction is not adequate to achieve the target by 2022. Hence, there was a need to look for new emerging, disaster-resilient, environment friendly, cost effective and speedy construction technologies which would form the basis of housing construction in India.

Hon'ble Prime Minister has envisaged a paradigm shift through technology transition using large scale construction under PMAY (U) as an opportunity to get the best available construction technologies across the globe. It has been envisioned to source technologies from all over the world and identify such technologies which would be suitable for adoption in India, given its unique geo-climatic conditions and user preferences based on diverse cultures. The shift in technology will address the large-scale housing construction in minimum time and minimum cost with efficient use of resources and environment friendly practices.

MoHUA launched "Global Housing Technology Challenge-India (GHTC-India)". The challenge has three components viz. i) Conduct of biennial Grand Expo-cum-Conference named Construction Technology India (CTI), ii) Identifying Proven Demonstrable Technologies from across the globe to construct Light House Projects (LHPs) iii) Promoting Potential Technologies (domestic) through the establishment of Affordable Sustainable Housing Accelerators- India (ASHA-India) for providing Incubation and Accelerator support.

GHTC-India was launched globally through a dedicated website, applications were invited online from proven technology providers. The Technical Evaluation Committee (TEC) interacted with applicants, who submitted online applications under Proven Demonstrable Technology category for GHTC-India. Technical presentations of their technologies were made before the TEC during CTI-2019 Expo-cum-Conference. MoHUA through TEC shortlisted basket of technologies suiting different geo-climatic conditions that could be considered for demonstration through actual ground implementation of six lighthouse projects located in six different States/UTs of PMAY(U) regions across the country.

The bids are being invited through this RFP to construct Light House projects (LHPs) for construction of about 1000 houses on approximately 2 Hectare of land within the framework of PMAY(U) on each selected site provided by States after using alternate technologies. The key challenge parameters for selection are the ability of the technology to deliver maximum

number of dwelling units in minimum time and in optimum cost. The project completion period in all respect is 12 months after handing over of site and approvals. All the statutory approvals will be provided by State/ULB/DA Officials on request of selected agency within 30 days from the date of award of contract to the selected agency to start timely construction work of LHPs as per contract as per committed LHP proposal to MoHUA.

An LHP shall mean a model housing project with about 1,000 houses built with alternate technology suitable to the geo-climatic and hazard conditions of the region. This will demonstrate and deliver ready to live-in houses with speed, economy and with better quality of construction in a sustainable manner. The minimum size of houses constructed under LHPs shall be up to 30 Square Meters carpet area in accordance with the prevailing guidelines of the Pradhan Mantri Awas Yojana)Urban.(However, carpet area of the house may increase as per the design proposed by selected agency/State/ULB/DA. Houses will be designed keeping in view the dimensional requirements laid down in National Building Code)NBC2016 with good aesthetics, proper ventilation, orientation, as required to suit the climatic conditions of the location and adequate storage space.

Each LHP will also include on-site infrastructure development such as internal roads, pathways, common green area, boundary wall, water supply, sewerage, drainage, rain water harvesting, solar lighting, external electrification, etc. as defined in scope of work. Cluster design may include innovative system of water supply and drainage, renewable energy sources with special focus on solar energy.

Convergence with other existing Centrally Sponsored Schemes and Missions such as Smart Cities Mission, Atal Mission for Rejuvenation and Urban Transformation (AMRUT), Swachh Bharat Mission (Urban), National Urban Livelihood Mission (NULM), Ujjwala, Ujala, Make in India shall be ensured during the designing of LHPs at each site.

The structural details shall be designed to meet the durability and safety requirements of applicable loads including earthquakes and cyclone and flood in accordance with the applicable Indian/International standards.

The selected Agency completing the project in all respect within 12 months will be rewarded with USD 20,000 each (equivalent INR as per prevailing exchange rate). A further incentive for early completion is being provided wherein agency who completes the project in less than 12 months will receive an incrementally higher bonus of USD 2,000 (equivalent INR as per prevailing exchange rate) for each less month than sanctioned 12 months.

Bids for each location will be invited on Engineering Procurement Construction (EPC) basis and selected agency shall submit Architectural drawings within 15 days and vetted structural design within 30 days after the approval of Architectural drawings, from the date of Letter of Award. The agency shall submit detailed drawings to the concerned authority of Ministry of Housing and Urban Affairs (MoHUA).

The project cost viz. the cost of Civil works along with internal infrastructure shall include planning and design charges, preparation of Detailed Project Report (hereinafter referred to as DPR) including Architectural and working drawings which are suitable for Construction, preparation of structural design, vetting of structural design from reputed institutions like IITs/ NITs, required testing from NABL accredited labs, contingency charges etc. Project cost shall also include infrastructure development cost including cost of construction of internal roads, pathways, common green area, boundary wall, water supply, water tank, site development, internal electrification, sewerage, drainage, firefighting system, lift shafts and machine room, lifts for multistory blocks, transformers along with HT/LT panel, Sewage Treatment Plant (STP) and DG set for emergency backup power for lift operation, etc.

These LHPs shall serve as open laboratories for different aspects of transfer of technologies to field application, such as planning, design, production of components, construction practices, testing etc. for both faculty and students of IITs /NITs /Engineering colleges /Planning and Architecture colleges, Builders, Professionals of Private and Public sectors and other stakeholders involved in such constructions .For this purpose, a sustained Information Education and Communication (IEC) activities shall be planned for Awareness and Promotion of new technologies through Multi-layered event publicity and web updates. IEC activities will be fully funded by Ministry of Housing and Urban Affairs (MoHUA).

During the process of housing construction, necessary data, information and other details will be collected for developing Schedule of Rates (SORs) (by Central Public Works Department (CPWD) and Building Materials and Technology Promotion Council (BMTPC). Selected agency will provide necessary data & technical details for preparation of SOR & standard specifications for the Technology.

The updates during the construction of LHPs shall also be shared with National Knowledge Network (NKN) for making the young generation familiarized with the overall process of use of innovative technologies and technological advancements.

After completion of the LHPs in all respect, it will be handed over to the concerned State Govt./ ULB/ DA by the selected agency after issuance of NOC from MoHUA. Further, normal routine maintenance of the LHPs will be responsibility of concerned State/ ULB/ DA and expenditure will be met by State Govt./ ULB/ DA. However, any remedial measures pertaining to structural issues/ major distress occurring in the project/ houses will be taken up by the selected agency at their own cost for a period of five years from the date of completion of project. After allotment of LHPs to the beneficiaries, the same will be maintained as per the provisions under PMAY (U) Guidelines.

To ensure sustainability after the houses are constructed, the selected agency shall ensure that an effective maintenance Manual is in place and necessary training and handholding is provided to State/ ULB/ DA officials,

regarding relevant maintenance measures of the projects within five years of defect liability period.

2.0 MoHUA hereby invites technical and financial bids for construction of LHPs at following six locations under GHTC-India using location specific exclusive alternate technologies(Annexure-A)which were shortlisted during the process of CTI-2019:

- i. Indore, Madhya Pradesh
- ii. Rajkot, Gujarat
- iii. Chennai, Tamil Nadu
- iv. Ranchi, Jharkhand
- v. Agartala, Tripura
- vi. Lucknow, Uttar Pradesh

The location plan/lay-out plans and other relevant drawings of each project are mentioned in Section G

3.0 Accordingly, MoHUA invites online Technical and Financial bids from agencies who are willing to adopt shortlisted technologies provided by the technology providers as given in Annexure-A for construction of Light House Projects containing Affordable Housing of about 1000 EWS housing units and associated services at above locations.

All residential buildings under LHPs shall be built only with the alternate technologies listed in Annexure-A. In case one proposed unique technology is not suitable for specific site as per structural and local geo-climatic requirement, the participating agency may use hybrid construction system other than conventional system subject to proof of its structural safety, fire safety, thermal performance and fulfillment of other functional requirements of the buildings. The participating agencies required to submit a detailed note on specification and code of practice and how the particular technology can be effectively used in proposed LHP.

3.1The Participating agency eligible for participating in the bidding process shall be from any one of the following two categories otherwise bids will be considered as non-responsive:

- i. **Category 1:** Single Business Entity shortlisted through the GHTC-India process.
- ii. **Category 2:** A Consortium/Joint venture of Business Entities (hereinafter referred to as “Consortium”) with one shortlisted agency from GHTC-India (category-1)

The term Participating agency would hereinafter apply to both the above-mentioned categories.

3.1.1 For the purpose of this RFP, the participating agency shall mean a business Entity incorporated under the Indian Companies Act 1956/2013 or incorporated under equivalent law abroad/Agency should be Participating Agency and should submit registration Certificates & GST Registration/incorporation under the governing legislation as applicable. The Agency shall be required to submit a

true copy of its Incorporation Certificate along with the Proposal.

3.2 For ease of evaluation, award and implementation of LHPs, the works at above six locations have been divided into six different packages based on location as below:

Site and Construction Area Details of 6 LHPs

S. No	Particulars	Unit	Madhya Pradesh	Gujarat	Tamil Nadu	Jharkhand	Tripura	Uttar Pradesh
1	Proposed Residential Area (Drawings attached)	S : Stilt G: Ground	S+8	S+13	G+5	G+8	G+6	G+13
2	Land (Plot) Area	In Sqm.	41920.00	39,599.00	33595.98	31,160.82	24,000.0	20000.0
3	Net Plot Area	In Sqm.	34,276.00	39,599.00	33595.98	31,160.82	24,000.0	20000.00
4	Permissible FSI	FSI	1.50	2.70	1.30	3.5	1.20	2.50
5	No. of DUs proposed	No.	1024	1144	1152	1008	1000	1040
6	Carpet Area per Dwelling Unit	Sqm.	34.98	39.77	26.58	29.85	30.0	30.00
7	Total Residential Built-up/ Covered Area including Circulation	Sqm.	56944.80	74,207.87	43476.48	38,004.54	43,590.60	47,788.0
8	Green Area	Sqm.	3445.00	2,500.00	5,043.09	6454.28	3,600.0	3000.0
Proposed Social Infrastructure/ Facility to be provided as per State requirement and NBC 2016 Norms by the selected agency								
9	Community Centre/ Hall Built-up Area	Sqm.	169.52	1270.80	As per layout	3168	1680.00	As per layout
10	Commercial Area/ Shop Built-up Area	Sqm.	-	986.75		-		As per layout
11	Aanganwadi/ Nursery/ Primary School Built-up Area	Sqm.	-			-		As per layout
12	Milk Booth Built-up Area	Sqm.	-			-		As per layout
13	Health Center	Sqm.	-			-		As per layout

Note: Number of houses, floors, built-up/ carpet area may vary as per the plan & location subject to approval from Competent Authority.

1. Suggestive Scope of Work for Construction of LHP 1 at Indore, Madhya Pradesh

- | | |
|---|----------------|
| 1. Proposed Residential Area (Drawings attached) | Stilt + 8 |
| 2. Land (Plot) Area | 41,920.00 sqm. |
| 3. Net Plot Area after deducting road widening area | 34,276.00 sqm. |
| 4. Permissible FSI | 1.50 |
| 5. No. of DUs proposed | 1024 |
| 6. Carpet Area per Dwelling Unit | 34.98 Sqm. |
| 7. Proposed Total Residential Built-up Area (including Circulation) | 56,944.80 Sqm. |
| 8. Proposed Green Area | 3,445.00 Sqm. |
| 9. Selected Agency will be required to provide Social Infrastructure with built-up area as mentioned | |
| i. Community Centre/ Hall Built-up Area | 169.52 Sqm |
| ii. Commercial Area/ Shop Built-up Area, Aanganwadi/ Nursery/ Primary School Built-up Area, Milk Booth Built-up Area, Health Center:
To be provided as per drawings mentioned in Section G and requirements of State | |
10. Selected Agency will be required to provide all necessary infrastructure facilities at site along with drawings but not limited to following mentioned as:
- i. Internal Water Supply
 - ii. Laying of Sewerage Pipe Line
 - iii. RCC storm water drain
 - iv. Provisions for Fire Fighting
 - v. Internal Electrification
 - vi. Internal Road & Pathway (CC Road and Bituminous Road)
 - vii. Providing Lifts in building blocks
 - viii. Landscaping of site
 - ix. Street light with fluorescent lamps
 - x. Solar Street Light System
 - xi. Sewerage Treatment Plant/ Septic Tank
 - xii. External Electrification
 - xiii. Water Supply System including underground water reservoir
 - xiv. Compound wall with Boundary Gates
 - xv. Horticulture facilities
 - xvi. Rain Water Harvesting
 - xvii. Solid Waste Management

2. Suggestive Scope of Work for Construction of LHP 2 at Rajkot, Gujarat

1. Proposed Residential Area (Drawings attached) Stilt floor + 13
2. Land (Plot) Area 39,599.00 sqm.
3. Permissible FSI 2.70
4. No. of DUs proposed 1144
5. Carpet Area per Dwelling Unit 39.77Sqm.
6. Proposed Total Residential Built-up Area (including Circulation) 74,207.87Sqm.
7. Proposed Green Area 2,500.00Sqm.
8. Selected Agency will be required to provide Social Infrastructure with built-up area as mentioned
 - i. Community Centre/ Hall Built-up Area 1270.80 Sqm.
 - ii. Commercial Area/ Shop Built-up Area, Aanganwadi/ Nursery/ Primary School Built-up Area, Milk Booth Built-up Area, Health Center: 986.75 Sqm.
9. Selected Agency will be required to provide all necessary infrastructure facilities at site along with drawings but not limited to following mentioned as:
 - i. Internal Water Supply
 - ii. Laying of Sewerage Pipe Line
 - iii. RCC storm water drain
 - iv. Provisions for Fire Fighting
 - v. Internal Electrification
 - vi. Internal Road & Pathway (CC Road and Bituminous Road)
 - vii. Providing Lifts in building blocks
 - viii. Landscaping of site
 - ix. Street light with fluorescent lamps
 - x. Solar Street Light System
 - xi. Sewerage Treatment Plant/ Septic Tank
 - xii. External Electrification
 - xiii. Water Supply System including underground water reservoir
 - xiv. Compound wall with Boundary Gates
 - xv. Horticulture facilities
 - xvi. Rain Water Harvesting
 - xvii. Solid Waste Management

3. Suggestive Scope of Work for Construction of LHP 3 at Chennai, Tamil Nadu

- | | |
|--|---------------|
| 1. Proposed Residential Area (Drawings attached) | Ground + 5 |
| 2. Land (Plot) Area | 33595.98 sqm. |
| 3. Permissible FSI | 1.30 |
| 4. No. of DUs proposed | 1152 |
| 5. Carpet Area per Dwelling Unit | 26.58 Sqm. |
| 6. Proposed Total Residential Built-up Area (including Circulation) | 43,476.48Sqm. |
| 7. Proposed Green Area | 5,043.09 Sqm. |
| 8. Selected Agency will be required to provide Social Infrastructure with built-up area as mentioned | |

Community Centre/ Hall Built-up Area, Commercial Area/ Shop Built-up Area, Aanganwadi/ Nursery/ Primary School Built-up Area, Milk Booth Built-up Area, Health Center: To be provided as per drawings mentioned in Section G and requirements of State

9. Selected Agency will be required to provide all necessary infrastructure facilities at site along with drawings but not limited to following mentioned as:
- i. Internal Water Supply
 - ii. Laying of Sewerage Pipe Line
 - iii. RCC storm water drain
 - iv. Provisions for Fire Fighting
 - v. Internal Electrification
 - vi. Internal Road & Pathway (CC Road and Bituminous Road)
 - vii. Providing Lifts in building blocks
 - viii. Landscaping of site
 - ix. Street light with fluorescent lamps
 - x. Solar Street Light System
 - xi. Sewerage Treatment Plant/ Septic Tank
 - xii. External Electrification
 - xiii. Water Supply System including underground water reservoir
 - xiv. Compound wall with Boundary Gates
 - xv. Horticulture facilities
 - xvi. Rain Water Harvesting
 - xvii. Solid Waste Management

4. Suggestive Scope of Work for Construction of LHP 4 at Ranchi, Jharkhand

- | | |
|---|------------------|
| 1. Proposed Residential Area (Drawings attached) | Ground floor + 8 |
| 2. Land (Plot) Area | 31,160.82 sqm. |
| 3. Permissible FSI | 3.50 |
| 4. No. of DUs proposed | 1008 |
| 5. Carpet Area per Dwelling Unit | 29.85 Sqm. |
| 6. Proposed Total Residential Built-up Area (including Circulation) | 38,004.54 Sqm. |
| 7. Proposed Green Area | 6,454.28 Sqm. |
| 8. Selected Agency will be required to provide Social Infrastructure with built-up area as mentioned | |
| i. Community Centre/ Hall Built-up Area | 3,168.00 Sqm. |
| ii. Commercial Area/ Shop Built-up Area, Aanganwadi/ Nursery/ Primary School Built-up Area, Milk Booth Built-up Area, Health Center | |
| To be provided as per drawings mentioned in Section G and requirements of State | |
| 9. Selected Agency will be required to provide all necessary infrastructure facilities at site along with drawings but not limited to following mentioned as: | |
| i. Internal Water Supply | |
| ii. Laying of Sewerage Pipe Line | |
| iii. RCC storm water drain | |
| iv. Provisions for Fire Fighting | |
| v. Internal Electrification | |
| vi. Internal Road & Pathway (CC Road and Bituminous Road) | |
| vii. Providing Lifts in building blocks | |
| viii. Landscaping of site | |
| ix. Street light with fluorescent lamps | |
| x. Solar Street Light System | |
| xi. Sewerage Treatment Plant/ Septic Tank | |
| xii. External Electrification | |
| xiii. Water Supply System including underground water reservoir | |
| xiv. Barbed wire fencing with compound gates | |
| xv. Horticulture facilities | |
| xvi. Rain Water Harvesting | |
| xvii. Solid Waste Management | |

5. Suggestive Scope of Work for Construction of LHP 5 at Agartala, Tripura

- | | |
|--|---------------|
| 1. Proposed Residential Area (Drawings attached) | Ground + 6 |
| 2. Land (Plot) Area | 24000.00 sqm. |
| 3. Permissible FSI | 1.2 |
| 4. No. of DUs proposed | 1000 |
| 5. Carpet Area per Dwelling Unit | 30.0 Sqm. |
| 6. Proposed Total Residential Built-up Area (including Circulation) | 43,590.60Sqm. |
| 7. Proposed Green Area | 3,600.00Sqm. |
| 8. Selected Agency will be required to provide Social Infrastructure with built-up area as mentioned | |

Community Centre/ Hall Built-up Area, Commercial Area/ Shop Built-up Area, Aanganwadi/ Nursery/ Primary School Built-up Area, Milk Booth Built-up Area, Health Center: To be provided as per drawings mentioned in Section G and requirements of State

9. Selected Agency will be required to provide all necessary infrastructure facilities at site along with drawings but not limited to following mentioned as:
- i. Internal Water Supply
 - ii. Laying of Sewerage Pipe Line
 - iii. RCC storm water drain
 - iv. Provisions for Fire Fighting
 - v. Internal Electrification
 - vi. Internal Road & Pathway (CC Road and Bituminous Road)
 - vii. Providing Lifts in building blocks
 - viii. Landscaping of site
 - ix. Street light with fluorescent lamps
 - x. Solar Street Light System
 - xi. Sewerage Treatment Plant/ Septic Tank
 - xii. External Electrification
 - xiii. Water Supply System including underground water reservoir
 - xiv. Compound wall with Boundary Gates
 - xv. Horticulture facilities
 - xvi. Rain Water Harvesting
 - xvii. Solid Waste Management

6. Suggestive Scope of Work for Construction of LHP 6 at Lucknow, Uttar Pradesh

- | | |
|--|----------------|
| 1. Proposed Residential Area (Drawings attached) | Stilt + 13 |
| 2. Land (Plot) Area | 20,000.00 sqm. |
| 3. Permissible FSI | 2.50 |
| 4. No. of DUs proposed | 1040 |
| 5. Carpet Area per Dwelling Unit | 34.50 Sqm. |
| 6. Proposed Total Residential Built-up Area (including Circulation) | 47,788.0 Sqm. |
| 7. Proposed Green Area | 3000.0 Sqm. |
| 8. Selected Agency will be required to provide Social Infrastructure with built-up area as mentioned | |

Community Centre/ Hall Built-up Area, Commercial Area/ Shop Built-up Area, Aanganwadi/ Nursery/ Primary School Built-up Area, Milk Booth Built-up Area, Health Center: To be provided as per drawings mentioned in Section G and requirements of State.

9. Selected Agency will be required to provide all necessary infrastructure facilities at site along with drawings but not limited to following mentioned as:
- i. Internal Water Supply
 - ii. Laying of Sewerage Pipe Line
 - iii. RCC storm water drain
 - iv. Provisions for Fire Fighting
 - v. Internal Electrification
 - vi. Internal Road & Pathway (CC Road and Bituminous Road)
 - vii. Providing Lifts in building blocks
 - viii. Landscaping of site
 - ix. Street light with fluorescent lamps
 - x. Solar Street Light System
 - xi. Sewerage Treatment Plant/ Septic Tank
 - xii. External Electrification
 - xiii. Water Supply System including underground water reservoir
 - xiv. Compound wall with Boundary Gates
 - xv. Horticulture facilities
 - xvi. Rain Water Harvesting
 - xvii. Solid Waste Management

Bid Document No.	<p>1. N-11019/11/2019-HFA-V-UD/ Computer No: 9061587/ Package I for Madhya Pradesh</p> <p>2. N-11019/11/2019-HFA-V-UD/ Computer No: 9061587/ Package II for Gujarat</p> <p>3. N-11019/11/2019-HFA-V-UD/ Computer No: 9061587/ Package III for Tamil Nadu</p> <p>4. N-11019/11/2019-HFA-V-UD/ Computer No: 9061587/ Package IV for Jharkhand</p> <p>5. N-11019/11/2019-HFA-V-UD/ Computer No: 9061587/ Package V for Tripura</p> <p>6. N-11019/11/2019-HFA-V-UD/ Computer No: 9061587/ Package VI for Uttar Pradesh</p>
Name of the Work (for each package)	Construction of about 1000 dwelling units with associated facilities and services by using any of the location specific shortlisted alternate technologies at six locations and maintaining them during the defect liability period.
Brief Scope of Work (form each package)	<p>Design and Construction of about 1000 number of EWS dwelling units including associated facilities and services by using any of the location specific shortlisted alternate Technologies as per the approved architectural and structural drawings including building and site infrastructure</p> <p>Arranging required material, machinery and manpower so as to complete the job within the quoted cost and specified time period.</p> <p>Maintenance of structure and lifts during defect liability period.</p>
Number of Houses and number of floors to be constructed at sites	Proposed number of houses and number of floors for all sites are indicative, after the finalization of layout plan by selected agency in consultation with State Govt./ MoHUA. The number of houses and floors may increase or decrease based on final approved layout.
Project Duration	15 Months (3 months for planning and taking statutory approvals from local authorities + 12 months for construction of each package from date of handing over of site and all statutory approvals)
Estimated Project Cost	Rs 125.0 Crore (Rupees One hundred and twenty five Crore) only
Earnest Money Deposit	<p>Rs 2.5 crore (Rupees two crore fifty lakh) only as per Note provided. EMD in form of Bank Guarantee to be issued in name of PAO (Sectt.), MoHUA payable at New Delhi</p> <p>Note: If one particular agency applies with one technology for more than one location, one EMD shall be submitted. However, if one agency is applying for one or more technologies with different locations, separate EMD shall be submitted.</p>

Last date & time of submission of Online Bid (for all packages)	Up to 20.08.2019
Period during which hard copy in original of EMD and Technical Bid to be submitted (for all packages)	Up to 20.08.2019 on or before the date of opening of Technical Bid
Date & Time of Opening of Technical Bid (for all packages)	21.08.2019
Pre-Bid Meeting & Venue (for all Sites)	29.07.2019 at Room No. 101 A, CPWD Conference Hall, Nirman Bhawan, New Delhi
Date & Time of Opening of Financial Bid (for all packages)	To be Intimated Later
Validity of offer	120 days from the date of opening of technical bid.

- a. The bid documents can be downloaded from www.eprocure.gov.in , www.ghtc-india.gov.in and www.mohua.gov.in
- b. Bids (technical bid) will be opened in descending order as per the land area of the project as given below.

Sl. No	Project Location	Land Area (sqm.)
1	Madhya Pradesh	41920.00
2	Gujarat	39599.00
3	Tamil Nadu	33595.98
4	Jharkhand	31160.82
5	Tripura	24000.00
6	Uttar Pradesh	20000.00

- c. The Participating Agency are free to participate in the bidding process for more than one location. However, in order to propagate the use of different alternate technologies across the regions, lowest Participating Agency with one of the shortlisted technologies would be allotted work in one region only using that specific technology.
- d. Once a particular technology (as distinct from technology provider) has been selected for one location, all the bids using the same technology for other locations shall not be opened. This will ensure that different locations will have separate technologies.

- e. All payments made by MoHUA will be in Indian currency. Any agency, including a foreign firm shall have no claim for payment in any other currency or to them.
- f. “Corrigendum/ Addendum/ Minutes of Pre-bid Meeting, if any, would appear only on the website and shall not be published in any News Paper”.

4.0 Minimum Eligibility Criteria for each package:

The interested Participating Agency should meet the following minimum qualifying criteria:

A. Work Experience:

- i. Experience of having successfully completed similar works during the last 7 years ending previous day of last date of submission of bids:
 - a. *Three similar works each costing not less than 40% of the estimated cost put to bid*
 - OR
 - b. *Two similar works each costing not less than 60% of the estimated cost put to bid*
 - OR
 - c. *One similar work costing not less than 80% of the estimated cost put to bid.*
- ii. “Similar works for Building Works” using proposed alternate technology/ hybrid proposed technology/ any other technology. The definition of similar work shall mean “Residential/Non-Residential buildings as per CPWD Works Manual 2019 and SOP (Mumty and Machine Room will not be counted as storey/height for this purpose, if Ground Floor is stilt, it will be counted as storey).
- iii. The past experience in similar nature of work should be supported by certificates issued by the client’s organization. In case the work experience is of Private sector the completion certificate shall be supported with copies of Letter of Award and copies of corresponding TDS certificates. In case of foreign firms, necessary evidences with respect to taxes may be attached appropriately.
- iv. The value of executed works shall be brought to the current level by enhancing the actual value of work done at a simple rate of 7% per annum, calculated from the date of completion to previous day of last day of submission of bids.

B. Financial Strength:

- i) The Average annual financial turnover of last consecutive fiscal years for last immediate 5 years shall be at least 50% of the estimated cost put to bid for each project location. The requisite Turnover shall be duly certified by

- a Chartered Accountant with his Seal/ signatures and registration number.
- ii) Net Worth of the participating agency as on 31st March of previous Financial Year should be positive.
 - iii) **Self certified copy of** Bank Solvency Certificate issued from Nationalized or any Schedule Bank should be at least 40% of Estimated Cost of the Project put to bid. The certificate should have been issued within 6 months from original last date of the submission of the bid.
 - iv) The Participating Agency should not have incurred any loss in more than two years during available last five consecutive balance sheets. The Participating Agency are required to upload and submit page of summarized Balance Sheet (Audited) and also page of summarized Profit & Loss Account (Audited) for last five years.

C. In case of Joint-venture/consortia of firms/companies:

1. A Consortium of a maximum of **three (3) members** of above such entities comprising one Lead Member with two other members shall be allowed and shall hereinafter be referred as "Consortium".
2. The Participating Agency should submit a Power of Attorney authorizing the signatory of the Application to commit the Participating Agency.
3. Bids submitted by a Consortium should comply with the following additional requirements:
 - a. The number of members in the Consortium would be limited to three (3);
 - b. The Application should contain the information required from each member;
 - c. The Application should include a description of the roles and responsibilities of all the members;
 - d. Members of the Consortium shall nominate one member as the Lead Member and that member must be an entity as defined above;
 - e. The Participating agency who has participated in this bid in its individual capacity or as part of a Consortium cannot participate as a separate agency of any other Consortium participating in this bid;
 - f. The members of the Consortium shall execute a Power of Attorney for Lead Member of Consortium.
 - g. The members of the Consortium shall enter into a Memorandum of Understanding (MoU), for the purpose of submission of the Application. The MoU should, inter alia,
 - i. Clearly outline the proposed roles and responsibilities of each member of the Consortium; and
 - ii. Include a statement to the effect that all members of the

Consortium shall be liable jointly and severally for the assignments arising out contract agreement therefore;

- iii. A copy of the MoU signed by all members should be submitted along with the technical bids. The MoU entered into between the members of the Consortium should contain the above requirements, failing which the Application shall be considered non-responsive.
4. A Participating agency or Consortium which has earlier been barred by MoHUA or blacklisted by any State /UT Government or Central Government / department / agency in India from participating in Bidding Process shall not be eligible to submit bids, either individually or as member of a Consortium, if such bar subsists as on the submission Due Date. The Participating agency or Consortium shall be required to furnish an affidavit that there is no such bar imposed and existing as on date.
5. A Participating Agency declared ineligible by multilateral agencies or Government of India or State Governments and debarred from providing the man power in India shall be ineligible to submit bids. In case the Participating agency or any member of Consortium is declared ineligible by multilateral agencies or Government of India or State Governments during the evaluation period then such bids shall be excluded from the evaluation process with MoHUA.
6. A Participating agency or member of Consortium should have, during the last three years, neither failed to perform on any agreement, as evidenced by imposition of a penalty or a judicial pronouncement or arbitration award against the Participating Agency or member of Consortium, nor been expelled from any project or agreement nor have had any agreement terminated for breach by such Participating Agency or member of Consortium.
7. Each participating agency shall submit only one proposal for each site. Any participating agency, which submits or participates in more than one bid for the same will be disqualified. However participating agency can submit bids for different sites.
8. The Application and all related correspondence and documents should be furnished by the participating Agency with the Application may be in any other language provided that these are accompanied by appropriate translations of the pertinent passages in the English language by approved/authorized/ licensed translator. Supporting material, which are not translated into English, may not be considered. For the purpose of interpretation and evaluation of the Application, the English language translation shall prevail.
9. Participating agency/consortium should be profit making organization. The audited balance sheet for the last three years may be attached with the technical bids, otherwise bids will be rejected.
10. Under GHTC-India, MoHUA have enlisted Indian Support

Partners who have relevant experience of construction and have shown interest in partnering for the purpose. The participating agency (ies) may explore possibilities of further associations, logistic supports, etc with these partners on their own. However, this enlistment is not a binding on any participating agency. The participating agencies are free to have JV/ consortium with any business entity from this enlistment or any other as the case may be. List of Indian support partners may be accessed at ghc-mhua@gov.in

5.0 Foreign Work Experience Certificate:

- i. In case the work experience is for the work executed outside India, the Participating Agency have to submit the completion/experience certificate issued by the owner duly signed & stamped and affidavit to the correctness of the completion/experience certificates. The Participating Agency shall also get the completion/experience certificates attested by the Indian Embassy/Consulate/High Commission in the respective country.
 - ii. In the event of submission of completion /experience certificate by the Participating Agency in a language other than English, the English translation of the same shall be duly authenticated by Chamber of Commerce of the respective country and attested by the Indian Embassy/Consulate / High Commission in the respective country.
 - iii. For the purpose of evaluation of Participating Agency, the conversion rate of such a currency into INR shall be the daily representative exchange rate published by the IMF as on 7 (Seven) days prior to the Last Date of Submission of bid including extension(s) given if any.
- 6.0 The Participating Agency are required to quote strictly as per terms and conditions, specifications, standards of alternate technologies provided in the bid documents and not to stipulate any deviations.
- 7.0 The Participating Agency are advised to submit complete details with their bids as Technical Bid Evaluation will be done on the basis of documents uploaded on website by the Participating Agency with the bids. The information should be submitted in the prescribed proforma. Bids with Incomplete /Ambiguous information will be rejected.
- 8.0 The Bank Guarantee for EMD submitted by the Participating Agency shall be strictly in the format prescribed in Form-G. In case, EMD is not found verbatim in the prescribed format, the bid will be liable for rejection.
- 9.0 The Participating Agency are advised in their own interest to submit their bid documents well in advance from last date/time of submission of bids so as to avoid problems which the Participating Agency may face in submission at last moment /during rush hours.
- 10.0 When it is desired by MoHUA to submit revised financial bid within the validity period then it shall be mandatory to submit revised

financial bid. If not submitted then the bid submitted earlier shall become invalid and EMD will be forfeited.

- 11.0 If the Participating Agency is found ineligible after opening of bids, his bid shall become invalid and cost of processing fee shall not be refunded.
- 12.0 Notwithstanding anything stated above, MoHUA reserves the right to assess the capabilities and capacity of the Participating Agency to perform the contract, in the overall interest of MoHUA. In case, Participating Agencies capabilities and capacities are not found satisfactory, MoHUA reserves the right to reject the bid.
- 13.0 **Certificate of Financial Turnover:** At the time of submission of bid, the Participating Agency shall upload Affidavit/Certificate from Chartered Accountant mentioning Financial Turnover of last 5 years or for the period as specified in the bid document. There is no need to upload entire voluminous balance sheet. However, one page of summarised balance sheet (Audited) and one page of summarized Profit & Loss Account (Audited) for last 05years shall be uploaded and submitted in hard copy also.
- 14.0 The Participating Agency (s) if required, may submit queries, if any, through E-mail and in writing to the bid inviting authority to seek clarifications upto date of pre-bid meeting from the date of uploading of bid document on website. MoHUA will reply to only those queries which are essentially required for submission of bids. MoHUA will not reply to the queries which are not considered fit like replies of which can be implied/found in the NIT/ Bid Documents or which are not relevant or in contravention to NIT/Bid Documents, queries received after 7days from the date of uploading of Bid on website. Technical Bids are to be opened on the scheduled dates. Requests for Extension of opening of Technical Bids will not be entertained.
- 15.0 Pre-bid meeting shall be held with the eligible and intending Participating Agency at stated time and venue as mentioned earlier in RFP. As a result of pre-bid meeting, certain modifications may be issued to all eligible Participating Agency by MoHUA corrigendum, if felt necessary. All modifications/addendums/corrigendum issued regarding this bidding process, shall be uploaded on website only and shall not be published in any Newspaper.
- 16.0 Attending the pre-bid meeting is optional. Participating Agency should contact MoHUA to arrange for their visit or to obtain additional information on the pre-bid meeting. Firms should ensure that these representatives are advised of the visit in adequate time to allow them to make appropriate arrangements. The Pre-Bid meeting shall be attended by the intending Participating Agency only and not by vendors/manufacturers. Further, the intending Participating Agency should depute their authorized person with authorization letter in original to attend the pre-bid meeting.

17.0 Integrity Pact

17.1 Integrity Pact duly signed by the Participating Agency shall be submitted as per ANNEXURE-III. Any bid without signed integrity Pact shall be liable for rejection.

18.0 List of Documents to be uploaded within the period of bid submission:

- a) Bank Guarantee of any Nationalized or all Commercial Scheduled Bank against EMD as per FORM-G.
- b) Memorandum as Annexure-IV.
- c) Unconditional Letter of Acceptance of Bid Conditions (in original) mentioned in Part 3 Financial Bid (On Letter Head of the Applicant/ Participating Agency).
- d) Integrity pact duly signed by the participating agency (Annexure-III). The Participating Agency are required to download the Integrity Pact as uploaded in the bid documents, and sign on the same, put rubber stamp/seal and upload the signed copy on e-bidding websites.
- e) Financial information of Participating Agency - FORM-A.
- f) Banker's Solvency Certificate- FORM-B.
- g) Details of Similar Works and work Experience Certificates- FORM-C.
- h) Structure and Organization Details of Firm – FORM E
- i) EMD Receipt Format – FORM F
- j) Documents regarding Net Worth of the Company/Firm.
- k) Form-Hof Contract Conditions -Affidavit duly notarized by Notary Public on Non Judicial Stamp Paper of Rs. 100 for correctness of Documents /Information.
- l) Power of Attorney of the person authorized for signing/submitting the bid.
- m) Valid GST registration/EPF registration/PAN NO.
- n) All pages of the entire Corrigendum (if any) duly signed by the authorized person.
- o) Pre-bid clarifications, if any.
- p) Registration Details of the participating agency as per GST Act in the State at the location of the Project– Form-I
- q) Details of Administrative and Technical staff to be associated in the project
- r) Geographical presence of the Participating agency

NOTE: All the uploaded documents should be in readable, printable and legible form failing which the Bids shall not be considered for evaluation. The relevant Annexure may be tabled with proper indexing.

19.0 (a) No Clarification will be sought in case of non-submission of EMD of requisite amount or Unconditional letter of acceptance or Affidavit for correctness of document/information. In such cases the bid shall be rejected out rightly without seeking any further clarification/document.

(b) All the uploaded and submitted documents shall be considered as duly signed by authorized representative of Participating Agency.

- 20 The bid submitted shall become invalid if:
- (i) The participating agency is found ineligible.
 - (ii) The participating agency does not deposit EMD with office of MoHUA
 - (iii) The participating agency does not upload all the documents as stipulated in the bid document.
 - (iv) If any discrepancy is noticed between the documents as uploaded at the time of submission of bid.
 - (v) Participating agency bid with deviation or conditional bid.

21.0 UNFAIR ADVANTAGE

- 21.1 **Penalty for use of Undue influence:** -The Firms undertakes that it has not given, offered or promised to give, directly or indirectly, any gift, consideration, reward, commission, fees, brokerage or inducement to any person in service of the MoHUA or otherwise in procuring the Contracts or forbearing to do or for having done or forborne to do any act in relation to the obtaining or execution of the present Contract or any other Contract with the Government of India for showing or forbearing to show favour or disfavor to any person in relation to the present Contract or any other Contract with the Government of India. Any breach of the aforesaid undertaking by the Firms or any one employed by him or acting on his behalf (whether with or without the knowledge of the Firms) or the commission of any offers by the Firms or anyone employed by him or acting on his behalf, as defined in Chapter IX of the Indian Penal Code, 1860 or the Prevention of Corruption Act,1986 or any other Act enacted for the prevention of corruption shall entitle the MoHUA to cancel the contract and all or any other contracts with the Firms and recover from the Firms the amount of any loss arising from such cancellation. A decision of the MoHUA or his nominee to the effect that a breach of the undertaking had been committed shall be final and binding on the Firms. Giving or offering of any gift, bribe or inducement or any attempt at any such act on behalf of the Firms towards any officer/employee of the MoHUA or to any other person in a position to influence any officer/employee of the MoHUA for showing any favour in relation to this or any other contract, shall render the Firms to such liability/ penalty as the MoHUA may deem proper, including but not limited to termination of the contract, imposition of penal damages, forfeiture of the Bank Guarantee and refund of the amounts paid by the MoHUA.
- 21.2 If a Firm could derive a competitive advantage from having provided consulting Assignment/Job related to the Assignment/Job in question and which is not defined as conflict of interest, the MoHUA shall make available to all Firms together with this RFP all information that would in that respect give such Firms any competitive advantage over competing Firms.
- 21.3 Canvassing in connection with the bid are strictly prohibited, and such canvassed bids submitted by the participating agency will be liable to be rejected and his earnest money shall be absolutely forfeited.
- 21.4 MoHUA reserves the right to reject any or all bids or cancel/withdraw the invitation for bid without assigning any reasons whatsoever

thereof. No claim of the participating agency whatsoever shall be entertained by MoHUA on this account.

21.5 In case of any query, please contact on Ph. No. 011-23063266 and E-mail: jshfa-mhupa@gov.in, dirhfa5-mhupa@gov.in, clsshfa5@yahoo.com and ghc-mhua@gov.in

(B.K. Mandal)
Under secretary to the Govt. of India
MoHUA
Tel: +91-11-23063285

Instructions for Online Bid Submission

1. All interested Participating Agency are requested to register themselves with the portal <http://eprocare.gov.in> and enroll their digital certificate with the user id for participation in the bid.
2. Participating Agency are requested to read following conditions in conjunction with various conditions, wherever applicable appearing with this bid invitation for e-Bidding. The conditions mentioned here in under shall supersede and shall prevail over the conditions enumerated elsewhere in the bid document.

3. How to submit On-line Bids/Offers electronically against e-Bidding?

Participating Agency are advised to read the following instructions for participating in the electronic bids directly through internet:

- i) Late and delayed Bids/Offers after due date/time shall not be permitted in e-Bidding system. No bid can be submitted after the last date and time of submission is over. The system time (IST) that will be displayed on e-bidding web page shall be the time and no other time shall be taken into cognizance.
- ii) Participating Agency are advised in their own interest to ensure that bids are uploaded in e-bidding system well before the closing date and time of bid.
- iii) No bid can be modified after the dead line for submission of bids.
- iv) No manual bids/offers along with electronic bids / offers shall be permitted.

4. What is a Digital Signature?

This is a unique digital code which can be transmitted electronically and primarily identifies a unique sender. The objective of digital signature is to guarantee that the individual sending the message is who he or she really claims to be just like the written signature. The Controller of Certifying Authorities of India (CCA) has authorized certain trusted Certifying Authorities (CA) who in turn allots on a regular basis Digital Signature Certificates (DSC).

5. Documents which are signed digitally are legally valid documents as per Indian IT Act (2000).**6. Why is a Digital Signature required?**

In order to bid for MOHUA e-bids all the vendors are required to obtain a legally valid Digital Certificate as per Indian IT Act from the licensed Certifying Authorities (CA) operating under the Root Certifying Authority of India (RCAI), Controller of Certifying Authorities (CCA) of India. The Digital Certificates is issued by CA in the name of a person authorized for filing Bids/Offers on behalf of his Company. A Vendor/ Participating

agency can submit their Bids/Offeres on-line only after digitally signing the bid/documents with the above allotted Digital Signatures.

7. Participating Agency have to procure Digital Signature Certificate (Class 3 or 2 with signing key uses) from any of the certifying Authorities in India.

8. Submission of Documents

- i) Participating Agency must submit on line offers by the date and time mentioned in the RFP at the website address stated therein.
- ii) Each E-Bid will provide access to Commercial as well as Price part of bid. Along with the Commercial part, Participating Agency can attach the required documents along with scan copy of Bank Guarantee for EMD with the bid in line with the Bid.
- iii) The successful bid submission can be ascertained once acknowledgement is given by the system through bid submission number after completing all the process and steps.
- iv) The bid have to be submitted online as well as physical submission. However, documents which necessarily have to be submitted in originals like Technical Proposal for each location, EMD and any other documents mentioned in the bid documents have to be submitted offline. Prices should not be submitted in a sealed envelope. MoHUA shall not be responsible in any way for failure on the part of the participating agency to follow the instructions.
- v) Financial Bid shall contain only price as per Schedule of Rates (in form of an excel sheet) without any condition. The lump sum rate along with tax and other components shall be filled up in figures and the total amount shall be automatically calculated and rounded off to the nearest rupee. It is to be noted that the Financial Bid shall contain only PRICES and no conditions whatsoever.
- vi) The online bid shall be uploaded through digital signatures by someone legally authorized to enter into commitment on behalf of the Participating agency. Participating agency shall upload among other documents, power of Attorney in favour of the person who is authorized to enter into commitments on behalf of the Participating agency.
- vii) It is advised that the participating agency upload small sized documents (preferably upto 5 MB) at a time to facilitate in easy uploading into e-biding site. MoHUA does not take any responsibility in case of failure of the participating agency to upload the documents within specified time of bid submission.
- (viii) The participating agency(ies) shall submit the Technical Bids in the format as mentioned in RFP **online** and also submit **its hard copy** in sealed envelope and mark the envelope as "RFP for Engineering Procurement Construction bid for the development and construction of EWS houses under Light House Projects in six states at selected site

under Global Housing Technology Challenge-India (GHTC-INDIA)". The proposal shall be submitted in Room No. 118-G, NBO Building, Nirman Bhawan, New Delhi in between 10.30 to 16:00 Hours and shall clearly mention name of Project, RFP No.

- (ix) The bid shall comprise a single packet containing the "EMD in form of Bank Guarantee" and "Technical Proposal" for each location shall be placed in hard binding and the pages shall be numbered serially. The document shall clearly mention Name of Bidder, LHP location and Alternate Technology proposed. Each page thereof shall be initialed in blue ink by the authorized signatory. The Proposal shall be marked as Original on right hand corner of Cover page of proposal in RED ink along with required documents.
- (x) It is also herewith informed that above mentioned RFP is being published on eprocure.gov.in for all six locations. During the process of evaluation of bid, all the conditions mentioned in RFP are not mutually exclusive and distinct. The participating agency(ies) are free to participate in the bidding process for more than one location using the same technology at different locations. Similarly, participating agency(ies) are free to participate in the bidding process for more than one location using the different technologies on different locations. However, in order to propagate the use of different alternate technologies across the regions, lowest Participating Agency with one of the shortlisted technologies would be allotted work in one region only using that specific technology. Once a particular technology (as distinct from technology provider) has been selected for one location, all the bids using the same technology for other locations shall not be opened. This will ensure that different locations will have separate technologies. Therefore, all the participating agency(ies) are requested to quote separately after downloading all published documents for all locations. Hence, MoHUA is publishing same RFP for all six locations with different template for financial bids. Participating agency(ies) is/are required to quote separately for different locations using same or different technology after using the different location wise financial template and upload the technical and financial proposals as per location mentioned
- xi) All participating agency(ies) are requested to submit the proof of same EMD in all technical bids as mentioned in RFP if they are quoting for more than one location with same technology. Similarly, if one agency is applying for one or more technologies for different locations, separate proof of EMD shall be submitted in all technical bids.

Broad categories of Technologies

S. No.	Technology Provider
A. Precast Concrete Construction System - 3D Precast volumetric	
1	M/s Katterra India Pvt. Ltd.
2	M/s Moducast Pvt. Ltd.
3	M/s Magicrete Building Solutions
4	M/s Ultratech Cement Ltd.
B. Precast Concrete Construction System - Precast components assembled at site	
5	M/s Larsen & Toubro
6	M/s B.G. Shirke Construction Technology Pvt. Ltd.
7	M/s Elematic India
8	M/s PG Setty Construction Technology Pvt. Ltd.
9	M/s Teemage Builders Pvt. Ltd.
10	M/s Nordicflex House
11	M/s Adlakha Associates Pvt. Ltd.
12	M/s William Ling
C. Light Gauge Steel Structural System & Pre-engineered Steel Structural System	
13	M/s Mitsumi Housing Pvt. Ltd.
14	M/s Everest Industries Ltd.
15	M/s JSW Steel Ltd.
16	M/s Society for Development of Composites
17	M/s Elemente Designer Homes
18	M/s MGI Infra Pvt. Ltd.
19	M/s RCM Prefab Pvt. Ltd.
20	M/s Nipani Infra and Industries Pvt. Ltd.
21	M/s Strawcture Eco
22	M/s Visakha Industries Ltd.
23	M/s RCC Infra Ventures Ltd.
24	M/s Jindal Steel & Power Ltd.
25	M/s HIL Ltd.
26	M/s Biltech Building Elements Ltd.
27	M/s SCG International India Pvt. Ltd.
28	M/s Pioneer Precast Solutions Private Limited
D. Prefabricated Sandwich Panel System	
29	M/s Worldhaus
30	M/s Bhargav Infrastructure Pvt.Ltd.
31	M/s Rising Japan Infra Private Limited
32	M/s Bau Panel Systems India Pvt. Ltd .
33	M/s BK Chemtech Engineering

S. No.	Technology Provider
34	M/s MSN Construction
35	M/s Beardshell Ltd.
36	M/s Covestro India Pvt. Ltd.
37	M/s Project Etopia Group
E. Monolithic Concrete Construction	
38	M/s Maini Scaffold Systems Pvt. Ltd.
39	M/s KumkangKind India Pvt. Ltd.
40	M/s S-form India Pvt. Ltd.
41	M/s ATS Infrastructure Ltd.
42	M/s Innovative housing & Infrastructure Pvt. Ltd.
43	M/s MFS formwork Systems Pvt. Ltd.
44	M/s Knest Manufacturers LLP.
45	M/s Outinord Formworks Pvt. Ltd.
46	M/s Brilliant Etoile
F. Stay In Place Formwork System	
47	M/s JK Structure
48	M/s FACT RCF Building Products Limited
49	M/s Coffor Construction Technology Pvt.Ltd
50	M/s Joseph Jebastin (Novel Assembler Private Limited),
51	M/s Reliable InsupackBuilding Solutions
52	M/s Kalzen Realty Pvt. Ltd.
53	M/s Fastbloc Building Systems
54	M/s FTS BuildtechPvt.Ltd.

PART-II
TECHNICAL BID

AAI	Airport Authority of India
BIM	Building Information Management
BIS	Bureau of Indian Standards
BSES	Local DISCOM
C & D Waste	Construction & Demolition Waste
COA	Council of Architecture
CPI	Consumer Price Index
CPWD	Central Public Works Department
DBR	Design Basis Report
DLP	Defects Liability Period
DSR	Delhi Schedule of Rates
EM	Earnest Money
EPC	Engineering Procurement Construction
CC	Contract Conditions
GPRA	General Pool Residential Accommodation
GRIHA	Green Rating for Integrated Habitat Assessment
HSE	Health Safety & Environment
IGBC	Indian Green Building Council
IPC	Interim Payment Certificate
IS	Indian Standard
MAS	Material at Site
MEP	Mechanical Electrical Plumbing
MoHUA	Ministry of Housing and Urban Affairs
MT	Metric Ton
MTC	Material Testing Certificate
NBC	National Building Code
NGT	National Green Tribunal
NIT	Notice Inviting Bid
OEM	Original Equipment Manufacturer
PPE	Personal Protection Equipment
SAP	Safety Action Plan
SOP	Schedule of Payment
SOQ	Schedule of Quantities
STP	Sewage Treatment Plant
TDS	Tax Deduction at Source
TPQAA	Third Party Quality Assurance Agency
UTTIPEC	Unified traffic & transportation infrastructure (plg. & engg.) Centre
WPI	Wholesale Price Index
WTP	Water Treatment Plant

Section-I

SCOPE OF WORK (GENERAL)

The scope of work includes architectural design, structural design, and detailed drawings of all required services for commencement of works, execution of work & services and handing over the assets after making them habitable in all aspects. The scope is inclusive of topographic survey, subsoil investigation and all ancillary works. The cost of labor, material, tools and plants and machinery required for execution of the whole project as per approved Layout plan & detailed design and drawings is within the scope of this work. The work is to be executed on EPC basis.

The brief scope of work is as follows:

- i) Architectural designing and obtaining all statutory/local body approvals required to start construction work as per built-up areas/ covered area given below:

Description	Carpet area to be constructed
A) No. of Houses- with necessary services as given below: i.) Lucknow, Uttar Pradesh ii.) Ranchi, Jharkhand iii.) Agartala, Tripura iv.) Indore, Madhya Pradesh v.) Rajkot, Gujarat vi.) Chennai, Tamil Nadu	As defined earlier in the RFP document.
B) Proposed Social Infrastructural Facilities	As defined earlier in the RFP document.

- ii) The general parameters of Architectural Designing:

Description	Permissible
Total Plot Area	As defined earlier in the RFP document
Carpet area per Unit	
Number of Storeys	
FAR proposed	
Proposed Number of Units	

- iii) The Layout Plan and Unit designs as attached as Section G forming part of this document are suggestive. The unit designs and layout plans may slightly deviate as per the technology requirement with the approval of MoHUA.

- iv) Conducting all studies as per the requirement at site such as :

- a. Topographical survey, Sub-soil investigation
- b. EIA, its clearance & compliance
- c. Others as per required

- v) Design of all Architectural, Civil/ Structural, Electrical & mechanical

- and Horticulture Services their integration and installation commissioning, including preparation of construction drawings, shop drawings, conducting necessary surveys and field tests to facilitate designing process, facilitate approval from MoHUA, construct the housing as per drawings approved by MoHUA.
- vi) Development of area, construction of boundary wall, internal roads, Street lighting, Parks and other amenities etc. required for safe living.
 - vii) The location plan, site layout and other related Architectural drawings is attached in this document as Section G.

Section-II

INFORMATION AND GUIDELINES FOR PARTICIPATING AGENCY

1.0 General:

- 1.1 Letter of transmittal and forms for deciding eligibility are given in Section III.
- 1.2 All information called for in the enclosed forms should be furnished against the relevant columns in the forms. If for any reason, information is furnished on a separate sheet, this fact should be mentioned against the relevant column. Even, if no information is to be provided in a column, a **'nil'** or **'no such case'** entry should be made in that column. If any particulars/query is not applicable in case of the participating agency, it should be stated as **'Not applicable'**. The Participating Agency are cautioned that not giving complete information called for in the application forms or not giving it in clear terms or making any change in the prescribed forms (or) deliberately suppressing the information may result in the bid being summarily disqualified. Bid made by telegram or telex and those received late will not be entertained.
- 1.3 The Technical bid should be in English. The participating agency should sign on each page of application, forms and documents before scanning & uploading and to ensure proper numbering and indexing.
- 1.4 Corrections if any should be made by neatly crossing out, initialing, dating and rewriting. Pages of the eligibility criteria document are numbered. Additional Sheets if any added by the Participating agency should also be numbered by him. They should be submitted as a package with signed letter of transmittal. Over writing should be avoided.
- 1.5 References, information and certificate from the respective clients certifying suitability, technical knowledge or capability of the participating agency should be signed by an authorized officer.
- 1.6 The participating agency may furnish any additional information, which he thinks is necessary to establish his capabilities to successfully complete envisaged work. He is, however advised not to furnish superfluous information. No information shall be entertained after submission of eligibility criteria document unless it is called for by the MoHUA.
- 1.7 If private works are shown in support of eligibility, certified copy of the TDS shall be submitted along with the experience certificate and the TDS amount shall tally with the actual amount of work done.
- 1.8 All participating agencies as a single entity or in JV/ Consortium have to meet all eligibility conditions mentioned in RFP comprehensively otherwise bid submitted will be rejected.

- 1.9 Two or more shortlisted technology providers as mentioned in Annexure A cannot collectively form a consortium/ JV

2.0 Final Decision Making Authority:

The MoHUA reserves the right to accept or reject any bid and to annul the process and reject all bids at any time without assigning any reason or incurring any liability to the participating agency's.

3.0 Addendum/ Corrigendum

Addendum/Corrigendum to the bid documents may be issued prior to the date of submission of the bid to clarify or effect modification in specification and/or contract terms included in various bid documents. The Participating agency shall suitably take into consideration such Addendum/Corrigendum while submitting his bid. The Participating agency shall return such Addendum/Corrigendum duly signed and stamped as confirmation of its receipt & acceptance and submit along with the bid document. All Addendum/Corrigendum shall be signed and stamped on each page by the Participating agency and shall become part of the bid and contract documents.

4.0 Site Visit:

It is incumbent upon the participating agency to visit the site at his own cost, and examine it and its surroundings by himself collect all information that is considered necessary for proper assessment, planning, design and construction of the project. It is expected that while bidding, the participating agency will take utmost care and diligence by visiting the sites and collecting the required parameters necessary. In case of any discrepancies later, MoHUA will not be held responsible. Contact persons of six locations are as follows:

S. No.	LHP-City, State	Name and Designation of Nodal Officer appointed by concerned State	Contact Information of Nodal Officer
1	Rajkot, Gujarat	Shri B.N. Patel, Project Specialist, Chief Engineer, Affordable Housing Mission	9978407349 (Bhavin Patel)
2	Ranchi, Jharkhand	Shri Rajeev Ranjan, I.A.S, Director/ Shri Sanjay Pandey, Assistant Director, Directorate of Municipal Administration, Jharkhand	7903796154
3	Indore, Madhya Pradesh	Shri Rajnish Kasera, Additional Commissioner (PMAY), Nagar Palika Nigam, Indore	7440446100
4	Lucknow, Uttar Pradesh	Shri Atul Kumar Singh Chauhan, Senior PO, SUDA	9958689889
5	Chennai, Tamil Nadu	Shri Rajasekar, Chief Engineer, Tamil Nadu Slum Clearance Board	9843020610
6	Agartala, Tripura	Shri D. Chakraborty, Chief Engineer, Urban Development Department, Govt. of Tripura	8837326330

5 Evaluation Criteria:

5.1 The details submitted by the participating agency will be evaluated in the following manner:-

5.1.1 The initial criteria prescribed in the RFP in respect of experience of similar work experience, eligibility, solvency and financial strength etc., will first be scrutinized and the participating agency's eligibility for the project will be determined.

5.1.2 The participating agency's qualifying the initial criteria as mentioned above will be evaluated as per the criteria mentioned below by scoring method on the basis of details furnished by the participating agency (ies)-

- a. Financial strength (Form 'A' & 'B')- **Max.25 marks**
- b. Experience in similar nature of work during last 7 **years**(Form 'C')- **Max.25 marks**
- c. Performance on works (Time over Run) (Form 'D') -**Max.10 marks**
- d. Performance on works (Quality) (Form 'D')- **Max.20 marks**
- e. Assessment in terms of Technical Competency, plant and machinery, consulting capabilities, approach to design and construction and work plan- **Max 20 marks**

Total

100 marks

5.1.3 To become eligible for short listing and for opening the Financial Bid, the participating agency must secure at least **50% (Fifty percent)** marks in each category and **60% (Sixty percent)** marks in aggregate.

5.1.4 MoHUA, however reserves the right to restrict the list of such qualified Participating Agency to any number deemed suitable by it.

5.1.5 After evaluation of Technical Bids, Financial Bids will be opened only of technically qualified participating agencies as per the criteria defined above and the work will be awarded to the lowest quoted (L1) participating agencies.

Note: The average value of performance of works for time over run and quality shall be taken on the basis of performance report of the eligible similar works.

1.0 Financial Information:

Participating agency should furnish the following financial information:

- i. Annual financial statement for the last Five years in Form 'A' and
- ii. Solvency certificate in Form 'B'

7.0 Experiences in Works Highlighting Experience in Similar Works:

7.1 Participating agency should furnish the following:

- i. List of all works of similar nature successfully completed during last **Seven years** in Form 'C'

- ii. Performance reports (corresponding to work mentioned in (Form-C) in Form-D. If needed, the participating agency may attach a separate certificate in this regard from performance report issuing authority.

8.0 Organization Information:

8.1 Participating agency is required to submit the information in respect of his/her/their organization in Form- 'E'.

8.1.1 The participating agency should have sufficient number of Technical and Administrative employees for proper execution of the contract. The participating agency should have to submit a list of these employees stating clearly how these would be involved in this work within 15 days of award of work.

9.0 Construction Plant and Equipment:

The Participating agency should furnish the list of construction plant and equipment required to be used in carrying out the work.

10.0 Letter of Transmittal:

The Participating agency should submit the letter of transmittal attached with the document.

11.0 Opening of Financial Bid:

After evaluation of pre-qualification documents, a list of short listed agencies who qualifies in technical bids will be prepared. There after the financial bids of only the qualified and technically acceptable Participating Agency shall be opened at the notified time, date and place in the presence of the qualified Participating Agency or their representatives if they desire to be present. The bid shall remain **valid for 120 days** from the date of opening of Technical bid (eligibility bid).

12.0 Award criteria:

12.1 The MoHUA reserves the right, without being liable for any damages or obligation to inform the participating agency to:

- 12.1.1 Amend the scope and value of contract to the participating agency.
- 12.1.2 Reject any or all the applications without assigning any reason.
- 12.1.3 Any effort on the part of the participating agency or his agent to exercise influence or to pressurize the MoHUA would result in rejection of his bid. Canvassing of any kind is prohibited.

ANNEXURE-II

Criteria for Evaluation of the performance of participating agency for Pre- Eligibility

S. No	Attributes	Max. Marks	Evaluation				
1	Financial Strength	20 Marks	1. Average Financial Turnover of last five consecutive years (fiscal) should be minimum 60 Cr				
	(Maximum 25 Marks)	05 Marks	2. Solvency Certificate of at least 40% of estimated project cost (each location)(Certification from Nationalized bank/ any Scheduled bank)				
2.	Past Experience in similar work (Maximum 25 Marks)	25 marks	1. Six (6) Project – 25 Marks 2. Less than Six (6) but more than Three (3) projects – 20 Marks 3. Less than or equal Three (3) projects – 15 Marks				
3.	Performance on works [Time Over Run (TOR)]: Maximum 10 marks						
	Parameter	Calculation for points	Score			Maximum Marks	
	If TOR = (i) Without levy of compensation (ii) With levy of compensation (iii) Levy of compensation not decided		1.00	2.00	3.00	>3.50	10
			10	7.5	5	5	
			10	2.5	0	0	
			10	5	0	0	
	$TOR = AT/ST$, where $AT = \text{Actual Time}$; $ST = \text{Stipulated Time}$. Note: Marks for value in between the stages indicated above is to be determined by straight line variation basis.						
4	Performance of works (Quality): Maximum 20 Marks						
	(i) Outstanding		20 Marks				
	(ii) Very Good		15 Marks				
	(iii) Good		10 Marks				
	(iv) Poor		0 Marks				
5	Assessment in terms of Technical Competency, plant and machinery, consulting capabilities, approach to design and construction with work plan: Max 20 Marks <i>(Attach the list of technical staffs, existing consultation partners, plant and machinery details, geographical presence and other moveable and immovable assets)</i>						

	(i) Technical staffs, existing consultation partners	05 Marks
	(ii) Plant and machinery details	05 Marks
	(iii) Geographical presence and other moveable and immovable assets	05 Marks
	(iv) Approach to design and construction, work plan based on design philosophy mentioned in scope of work	05 Marks
Grand Total		100 Marks

SECTION-III: TEMPLATE OF FORMS

LETTER OF TRANSMITTAL

From

To

.....

Name of Work:

Sir,

Having examined details given in the RFP for the above work, I/we hereby submit the relevant information.

1. I/We hereby certify that all the statements made and information supplied in the enclosed Forms A to I and accompanying statement are true and correct.
2. I/we have furnished all information and details necessary for eligibility and have no further pertinent information to supply.
3. I/we submit the requisite certified solvency certificate and authorize theto approach the Bank issuing the solvency certificate to confirm the correctness thereof. I/We also authorizeto approach individuals, MoHUA, firms and corporation to verify our competence, work experience, and general reputation.

I/we submit the following certificates in support of our suitability, technical knowledge and capability for having successfully completed the following works:

Certificate

It is certified that the information given in the enclosed eligibility bid are correct. It is also certified that I/We shall be liable to be debarred, disqualified/cancellation of enlistment in case any information furnished by me/us found to be incorrect.

Enclosures:

Date of submission

**Seal of participating agency &
Signature(s)
of participating agency(s)**

FINANCIAL INFORMATION

Name of the firm/Participating agency.....:

- I. Financial Analysis-Details to be furnished duly supported by figures in balance sheet/profit & loss account for the last five years duly certified and audited by the Chartered Accountants, as submitted by the applicant to the Income Tax Department (Copies to be attached).

Rs.in Lakh

Sl. No.	Particulars	Financial Years				
		2014-15	2015-16	2016-17	2017-18	2018-19
i)	Turnover of construction works					
ii)	Profit/ Loss					

- II. Financial arrangements for carrying out the proposed work.
- III. Solvency Certificate from Bankers of participating agency in the prescribed Form "B"

SIGNATURE OF PARTICIPATING AGENCY(S)
Signature of Chartered Accountant with Seal

FORM OF BANKERS' SOLVENCY CERTIFICATE FROM A SCHEDULED BANK

This is to certify that to the best of our knowledge and information that M/s./Shri having marginally noted address, a customer of our bank are/is respectable and can be treated as good for any engagement up to a limit of Rs -----).

This certificate is issued without any guarantee or responsibility on the bank or any of the officers.

(Signature) For the Bank

NOTE: (1) Bankers certificate should be on letter head of the Bank, addressed to MoHUA.....

(2) In case of partnership firm, certificate should include names of all partners as recorded with the Bank.

DETAILS OF ELIGIBLE SIMILAR NATURE OF WORKS COMPLETED IN LAST SEVEN YEARS ENDING PREVIOUS DAY OF LAST DATE OF SUBMISSION OF BID

Name of the firm/Participating agency.....

S.No.	Details
1.	Name of work/project and location
2.	Owner or sponsoring organization
3.	Cost of work in Rs. in Crores
4.	Date of commencement as per contract
5.	Stipulated date of completion
6.	Actual date of completion
7.	*Litigation/arbitration cases pending/in progress with details
8.	Name and Address (Postal & E-mail)/telephone number of officer to whom reference may be made
9.	Whether the work was done on back to back basis

Certified that the above list of works is complete and no work has been left out and that the information given is correct to my/our knowledge and belief.

SIGNATURE OF PARTICIPATING AGENCY(S)

WITH STAMP

***indicate gross amount claimed and amount awarded by the Arbitrator.**

PERFORMANCE REPORT OF WORKS REFERRED IN FORM-C

1.	Name of work/Project & Location	
2.	Agreement No.	
3.	Estimated Cost	
4.	Bided Cost	
5.	Date of Start	
6.	Date of completion	
	i) Stipulated Date of Completion (as mentioned in work order)	
	ii) Actual Date of Completion	
7.	i) Whether case of levy of compensation for delay has been decided or not	Yes/ No.
	ii) If decided, amount of compensation levied for delayed completion, if any.	
8.	Performance Report	
	1) Quality of Work	Outstanding/Very Good/Good/Poor
	2) Financial Soundness	Outstanding/Very Good/ Good/Poor
	3) Technical Proficiency	Outstanding/Very Good/ Good/Poor
	4) Resourcefulness	Outstanding/Very Good/ Good/Poor
	5) General Behavior	Outstanding/Very Good/ Good/ Poor
Dated:		Competent Authority

Note: This certificate should be issued by the owner of the project. However, the quality and performance shall be established by the committee constituted by MoHUA by conducting site visits to the selected project sites

STRUCTURE & ORGANIZATION

1.	Name & Address of the participating agency	
2.	Telephone No. / Email id /Telex No./Fax No.	
3.	Legal status of the participating agency(attach copies of original document defining the legal status).	
	a) A Business Entity	
	b) A Proprietary Firm	
	c) A Firm in Partnership	
	d) A Limited Company or Corporation	
4.	Particulars of registration with various Government bodies (attach attested photo-copy).	
	ORGANIZATION/PLACE OF REGISTRATION	REGISTRATION No.
	1.	
	2.	
	3.	
5.	Names and Titles of Directors & Officers with designation to be concerned with this work.	
6.	Designation of individuals authorized to act for the organization.	
7.	Has the participating agency or any constituent partner in case of partnership firm, ever abandoned the awarded work before its completion? If so, give name of the project and reasons for abandonment.	
8.	Has the participating agency, or any constituent partner in case of partnership firm/limited company/ joint venture, ever been convicted by the court of law? If so, give details.	
9.	In which field of Civil Engineering Construction, the participating agency has specialization and interest?	
10.	Any other information considered necessary but not included above.	

Signature of participating agency(s) with stamp

EMD RECEIPT FORMAT

Receipt of deposition of original Bank Guarantee as EMD

Receipt No.....* /date.....*

Name of Work:

1. **RFP No:**

2. **Amount of Earnest Money Deposit:**

i) In the form of Bank Guarantee Rs.....issued by.....
Date....(as per Form- G)

3. **Last date of submission of bid:**

1. **Name of Participating agency:**#

2. **Total EMD Deposited:** #

3. **Amount of Earnest Money Deposit:** #

i) In the form of Bank Guarantee Rs.....issued by.....
Date....(as per Form- G)

4. **Date of submission of EMD:**.....#

Signature, Name and Designation of EMD receiving officer
(Along with Office stamp)

FORM OF EARNEST MONEY DEPOSIT (BANK GUARANTEE BOND)

WHEREAS, participating agency..... (Name of Participating agency) (herein after called "the Participating agency") has submitted his bid dated (date) for the construction of (name of work) (herein after called "the bid")

KNOW ALL PEOPLE by these presents that we (name of bank) having our registered office at (herein after called "the Bank") are bound unto**(name of office)** in the sum of Rs. (Rs. in words) for which payment well and truly to be made to the said**(name of beneficiary)**, the Bank binds itself, his successors and assigns by these presents.

SEALED with the Common Seal of the said Bank this day of 2.... THE CONDITIONS of this obligation are:

- (1) If after bid opening of bid; the Participating agency withdraws, his bid during the period of validity of bid (including extended validity of bid) specified in the Form of Bid;
- (2) If the Participating agency having been notified of the acceptance of his bid by the

(a) Fails or refuses to execute the Form of Agreement in accordance with the Instructions to Participating agency, if required;

OR

(b) Fails or refuses to furnish the Performance Guarantee, in accordance with the provisions of bid document and Instructions to Participating agency,

We undertake to pay to the either up to the above amount or part thereof upon receipt of his first written demand, without the having to substantiates his demand, provided that in his demand will note that the amount claimed by him is due to him owing to the occurrence of one or any of the above conditions, specifying the occurred condition or conditions.

This Guarantee will remain in force up to and including the date * after the deadline for submission of bid as such deadline is stated in the Instructions to Participating agency or as it may be extended by the, notice of which extension(s) to the Bank is hereby waived. Any demand in respect of this Guarantee should reach the Bank not later than the above date.

DATE

SIGNATURE OF THE BANK

WITNESS

SEAL

(SIGNATURE, NAME AND ADDRESS)

*Date to be worked out on the basis of validity period of 6 months from the last date of uploading the bid.

AFFIDAVIT

(To be submitted by bidder on non-judicial stamp paper of Rs.100/(Rupees Hundred only) duly attested by Notary Public)

Affidavit of Mr.S/o
R/o

I, the deponent above named do hereby solemnly affirm and declare as under:

1. That I am the Proprietor/Authorized signatory of M/s
Having its Head Office/Regd. Office at
2. That the information/documents/Experience certificates submitted by M/s..... along with the tender for (*Name of work*).....
To MoHUA are genuine and true and nothing has been concealed.
3. I shall have no objection in case MoHUA verifies them from issuing authority(ies). I shall also have no objection in providing the original copy of the document(s), in case MoHUA demands so for verification.
4. I hereby confirm that in case, any document, information & / or certificate submitted by me found to be incorrect / false / fabricated, MoHUA at its discretion may disqualify / reject / terminate the bid/contract and also forfeit the EMD / All dues.
5. I shall have no objection in case MoHUA verifies any or all Bank Guarantee(s) under any of the clause(s) of Contract including those issued towards EMD and Performance Guarantee from the Zonal / Branch office of issuing Bank and I/We shall have no right or claim on my submitted EMD before MoHUA receives said verification.
6. That the Bank Guarantee issued against the EMD issued by (name and address of the Bank) is genuine and if found at any stage to be incorrect / false / fabricated, MoHUA shall reject my bid, cancel pre-qualification and debar me from participating in any future tender for three years.
7. I hereby confirm that our firm /company is not blacklisted/ barred /banned from tendering by MoHUA. If this information is found incorrect, MoHUA at its discretion may disqualify / reject / terminate the bid/contract.
8. The person who has signed the tender documents is our authorized representative. The Company is responsible for all of his acts and omissions in the tender.

I,, the Proprietor / Authorised signatory of M/s..... do hereby confirm that the contents of the above Affidavit are true to my knowledge and nothing has been concealed there from..... and that no part of it is false.

DEPONENT

Verified atthis.....day of

DEPONENT

ATTESTED BY (NOTARY PUBLIC)

GST Registration Details of Contractor/Vender	
Name	
Address (As per registration with GST)	
City	
Postal Code	
Region/State (Complete State Name)	
Permanent Account Number	
GSTIN ID/Provisional ID No.: (copy of Acknowledgement required)	
Type of Business (As per registration with GST)	
Service Accounting Code/HSN Code:	
Contact Person	
Phone Number and Mobile Number	
Email ID	
Compliance Rating (if updated by GSTN)	

INTEGRITY PACT

To,
.....,
.....

Sub: Submission of Bid for the work of

Dear Sir,

I/We acknowledge that MoHUA is committed to follow the principles thereof as enumerated in the Integrity Agreement enclosed with the bid/bid document.

I/We agree that the RFP is an invitation to offer made on the condition that I/We will sign the enclosed integrity Agreement, which is an integral part of bid documents, failing which I/We will stand disqualified from the bidding process. I/We acknowledge that THE MAKING OF THE BID SHALL BE REGARDED AS AN UNCONDITIONAL AND ABSOLUTE ACCEPTANCE of this condition of the RFP.

I/We confirm acceptance and compliance with the Integrity Agreement in letter and spirit and further agree that execution of the said Integrity Agreement shall be separate and distinct from the main contract, which will come into existence when bid/bid is finally accepted by MoHUA. I/We acknowledge and accept the duration of the Integrity Agreement, which shall be in the line with Article 1 of the enclosed Integrity Agreement.

I/We acknowledge that in the event of my/our failure to sign and accept the Integrity Agreement, while submitting the bid/bid, MoHUA shall have unqualified, absolute and unfettered right to disqualify the Participating agency/participating agency and reject the bid/bid is accordance with terms and conditions of the bid/ bid.

Yours faithfully

(Duly authorized signatory of the Participating agency)

INTEGRITY AGREEMENT

(To be signed by the participating agency and same signatory competent / authorized to sign the relevant contract on behalf of MoHUA)

This Integrity Agreement is made at on this..... day of 20.....

BETWEEN

.....,
....., (Name of Office) MoHUA,
.....,
(Hereinafter referred as the 'Principal/Owner', which expression shall unless repugnant to the meaning or context hereof include its successors and permitted assigns)

AND

.....
..... (Name and Address of the Individual/firm/Company)
through
(Hereinafter referred to as the (Details of duly authorized signatory)
"Participating agency/Participating agency" and which expression shall unless repugnant to the meaning or context hereof include its successors and permitted assigns)

Preamble

WHEREAS the Principal / Owner has floated the Bid (RFP No.) (hereinafter referred to as "Bid/Bid") and intends to award, under laid down organizational procedure, contract for (Name of work) hereinafter referred to as the "Contract".

AND WHEREAS the Principal/Owner values full compliance with all relevant laws of the land, rules, regulations, economic use of resources and of fairness/transparency in its relation with its Participating agency(s) and Participating agency(s).

AND WHEREAS to meet the purpose aforesaid both the parties have agreed to enter into this Integrity Agreement (hereinafter referred to as "Integrity Pact" or "Pact"), the terms and conditions of which shall also be read as integral part and parcel of the Bid/Bid documents and Contract between the parties.

NOW, THEREFORE, in consideration of mutual covenants contained in this Pact, the parties hereby agree as follows and this Pact witnesses as under:

Article 1: Commitment of the Principal/Owner

(1)MoHUA commits itself to take all measures necessary to prevent corruption and to observe the following principles:

- (a) No employee of the Principal/Owner, personally or through any of his/her family members, will in connection with the Bid, or the

execution of the Contract, demand, take a promise for or accept, for self or third person, any material or immaterial benefit which the person is not legally entitled to.

- (b) MoHUA will, during the Bid process, treat all Participating agency(s) with equity and reason. MoHUA will, in particular, before and during the Bid process, provide to all Participating agency(s) the same information and will not provide to any Participating agency(s) confidential / additional information through which the Participating agency(s) could obtain an advantage in relation to the Bid process or the Contract execution.

The Principal/Owner shall endeavor to exclude from the Bid process any person, whose conduct in the past has been of biased nature.

- (2) If MoHUA obtains information on the conduct of any of its employees which is a criminal offence under the Indian Penal code (IPC)/Prevention of Corruption Act, 1988 (PC Act) or is in violation of the principles herein mentioned or if there be a substantive suspicion in this regard, the Principal/Owner will inform the Chief Vigilance Officer/Competent Authority and in addition can also initiate disciplinary actions as per its internal laid down policies and procedures.

Article 2: Commitment of the Participating agency(s)/Participating agency(s)

- (1) It is required that each Participating agency/Participating agency (including their respective officers, employees and agents) adhere to the highest ethical standards, and report to the Government / Department all suspected acts of fraud or corruption or Coercion or Collusion of which it has knowledge or becomes aware, during the bidding process and throughout the negotiation or award of a contract.
- (2) The Participating agency(s)/Participating agency(s) commits himself to take all measures necessary to prevent corruption. He commits himself to observe the following principles during his participation in the Bid process and during the Contract execution:
 - (a) The Participating agency(s)/Participating agency(s) will not, directly or through any other person or firm, offer, promise or give to any of the Principal/Owner's employees involved in the Bid process or execution of the Contract or to any third person any material or other benefit which he/she is not legally entitled to, in order to obtain in exchange any advantage of any kind whatsoever during the Bid process or during the execution of the Contract.
 - (b) The Participating agency(s)/Participating agency(s) will not enter with other Participating agency(s) into any undisclosed agreement or understanding, whether formal or informal. This applies in particular to prices, specifications, certifications, subsidiary contracts, submission or non-submission of bids or any other actions to restrict competitiveness or to cartelize in the bidding process.
 - (c) The Participating agency(s)/Participating agency(s) will not commit any offence under the relevant IPC/PC Act. Further the Participating agency(s)/ Contract(s) will not use improperly, (for the purpose of competition or personal gain), or pass on to others, any information or

- documents provided by the Principal/Owner as part of the business relationship, regarding plans, technical proposals and business details, including information contained or transmitted electronically.
- (d) The Participating agency(s)/Participating agency(s) of foreign origin shall disclose the names and addresses of agents/ representatives in India, if any. Similarly Participating agency(s)/Participating agency(s) of Indian Nationality shall disclose names and addresses of foreign agents/representatives, if any. Either the agent on behalf of the foreign principal or the foreign principal directly could bid in a bid but not both. Further, in cases where an agent participate in a bid on behalf of one manufacturer, he shall not be allowed to quote on behalf of another manufacturer along with the first manufacturer in a subsequent/parallel bid for the same item.
 - (e) The Participating agency(s)/Participating agency(s) will, when presenting his bid, disclose any and all payments he has made, is committed to or intends to make to agents, brokers or any other intermediaries in connection with the award of the Contract.
- (3) The Participating agency(s)/Participating agency(s) will not instigate third persons to commit offences outlined above or be an accessory to such offences.
 - (4) The Participating agency(s)/Participating agency(s) will not, directly or through any other person or firm indulge in fraudulent practice means a willful misrepresentation or omission of facts or submission of fake/forged documents in order to induce public official to act in reliance thereof, with the purpose of obtaining unjust advantage by or causing damage to justified interest of others and/or to influence the procurement process to the detriment of the Government interests.
 - (5) The Participating agency(s)/Participating agency(s) will not, directly or through any other person or firm use Coercive Practices (means the act of obtaining something, compelling an action or influencing a decision through intimidation, threat or the use of force directly or indirectly, where potential or actual injury may befall upon a person, his/ her reputation or property to influence their participation in the bidding process).

Article 3: Consequences of Breach

Without prejudice to any rights that may be available to the Principal/Owner under law or the Contract or its established policies and laid down procedures, the Principal/Owner shall have the following rights in case of breach of this Integrity Pact by the Participating agency(s)/Participating agency(s) and the Participating agency/ Participating agency accepts and undertakes to respect and uphold the Principal/Owner's absolute right:

- (1) If the Participating agency(s)/Participating agency(s), either before award or during execution of Contract has committed a transgression through a violation of Article 2 above or in any other form, such as to put his reliability or credibility in question, the Principal/Owner after giving 14 days notice to the participating agency shall have powers to disqualify the

Participating agency(s)/Participating agency(s) from the Bid process or terminate/determine the Contract, if already executed or exclude the Participating agency/Participating agency from future contract award processes. The imposition and duration of the exclusion will be determined by the severity of transgression and determined by the Principal/Owner. Such exclusion may be forever or for a limited period as decided by the Principal/Owner.

- (2) Forfeiture of EMD/Performance Guarantee/Security Deposit: If the Principal/Owner has disqualified the Participating agency(s) from the Bid process prior to the award of the Contract or terminated/determined the Contract or has accrued the right to terminate/determine the Contract according to Article 3(1), the Principal/Owner apart from exercising any legal rights that may have accrued to the Principal/Owner, may in its considered opinion forfeit the entire amount of Earnest Money Deposit, Performance Guarantee and Security Deposit of the Participating agency/Participating agency.
- (3) Criminal Liability: If the Principal/Owner obtains knowledge of conduct of a Participating agency or Participating agency, or of an employee or a representative or an associate of a Participating agency or Participating agency which constitutes corruption within the meaning of IPC Act, or if the Principal/Owner has substantive suspicion in this regard, the Principal/Owner will inform the same to law enforcing agencies for further investigation.

Article 4: Previous Transgression

- (1) The Participating agency declares that no previous transgressions occurred in the last 5 years with any other Company in any country confirming to the anticorruption approach or with Central Government or State Government or any other Central/State Public Sector Enterprises in India that could justify his exclusion from the Bid process.
- (2) If the Participating agency makes incorrect statement on this subject, he can be disqualified from the Bid process or action can be taken for banning of business dealings/ holiday listing of the Participating agency/Participating agency as deemed fit by the Principal/ Owner.
- (3) If the Participating agency/Participating agency can prove that he has resorted/recouped the damage caused by him and has installed a suitable corruption prevention system, the Principal/Owner may, at its own discretion, revoke the exclusion prematurely.

Article 5: Equal Treatment of all Participating Agency/Participating agencies/Sub-participating agency(s)

- (1) The Participating agency(s)/Participating agency(s) undertake(s) to demand from all sub participating agency a commitment in conformity with this Integrity Pact. The Participating agency/Participating agency shall be responsible for any violation(s) of the principles laid down in this agreement/Pact by any of its sub participating agency/sub-vendors.

- (2) The Principal/Owner will enter into Pacts on identical terms as this one with all Participating Agency and Participating agency.
- (3) The Principal/Owner will disqualify Participating Agency, who do not submit, the duly signed Pact between the Principal/ Owner and the participating agency, along with the Bid or violate its provisions at any stage of the Bid process, from the Bid process.

Article 6- Duration of the Pact

This Pact begins when both the parties have legally signed it. It expires for the Participating agency/Vendor five years after the completion of work under the contract or till the continuation of defect liability period, whichever is more and for all other Participating Agency, till the Contract has been awarded. If any claim is made/lodged during the time, the same shall be binding and continue to be valid despite the lapse of this Pacts as specified above, unless it is discharged/determined by the Competent Authority, MoHUA.

Article 7- Other Provisions

- (1) This Pact is subject to Indian Law, place of performance and jurisdiction is the Head quarters of the Division of the Principal/Owner, who has floated the Bid.
- (2) Changes and supplements need to be made in writing. Side agreements have not been made.
- (3) If the Participating agency is a partnership or a consortium, this Pact must be signed by all the partners or by one or more partner holding power of attorney signed by all partners and consortium members. In case of a Company, the Pact must be signed by a representative duly authorized by board resolution.
- (4) Should one or several provisions of this Pact turn out to be invalid; the remainder of this Pact remains valid. In this case, the parties will strive to come to an agreement to their original intensions.
- (5) It is agreed term and condition that any dispute or difference arising between the parties with regard to the terms of this Integrity Agreement/Pact, any action taken by the Owner/Principal in accordance with this Integrity Agreement/Pact or interpretation thereof shall not be subject to arbitration.

Article 8- LEGAL AND PRIOR RIGHTS

All rights and remedies of the parties hereto shall be in addition to all the other legal rights and remedies belonging to such parties under the Contract and/or law and the same shall be deemed to be cumulative and not alternative to such legal rights and remedies aforesaid. For the sake of brevity, both the Parties agree that this Integrity Pact will have precedence over the

Bid/Contact documents with regard any of the provisions covered under this Integrity Pact.

IN WITNESS WHEREOF the parties have signed and executed this Integrity Pact at the place and date first above mentioned in the presence of following witnesses:

.....
(For and on behalf of Principal/Owner)

.....
(For and on behalf of Participating agency/Participating agency)

WITNESSES:

1.
(signature, name and address)

2.
(signature, name and address)

Place: _____ Dated _____ :

PART-III

FINANCIAL BID

Government of India
Ministry of Housing and Urban Affairs

EPC & Contract for Works

Name of Work: _____

- (i) **To be uploaded on website: www.eprocure.gov.in**
- (ii) **To be opened in the presence of Participating Agency who may be present in the office of JS&MD (HFA)**

BID

I/We have read and examined the notice inviting bid, including all documents and amendments up to the last date of submission of bids, clauses of contract, special conditions, bill of quantities & other documents and rules referred to in the contract conditions and all other contents in the bid document for the work.

I/We hereby bid for the execution of the work specified for MoHUA within the time specified in viz., schedule of quantities and in accordance in all respect with the specifications, designs, drawing and instructions and contract conditions given in this document.

We agree to keep the bid open for one hundred twenty **(120) days** from the date of opening of technical bid and not to make any modification in its terms and conditions.

A copy of receipt of deposition of earnest money **Rs 2.5 Crore** in receipt Treasury Challan/Deposit at call Receipt of scheduled bank/Fixed Deposit receipt of scheduled bank/Demand Draft or pay order or Banker's cheque of scheduled bank/bank guarantee issued by a scheduled bank is scanned and uploaded. If I/We, fail furnish to the prescribed performance guarantee within prescribed period, I/We agree that the said President of India or his successors, in office shall without prejudice to any other right or remedy, be at liberty to forfeit the said Earnest Money absolutely. Further, if I/We fail to commence work as specified, I/We agree that President of India or the successors in office shall without prejudice to any other right or remedy available in law, be at liberty to forfeit the said performance guarantee absolutely, the said performance guarantee shall be a guarantee to execute all the works referred to in the bid documents upon the terms and conditions contained or referred to those in excess of that limit at the rates to be determined in accordance with the provision contained in clause 12.2 and 12.3 (as modified) of the bid form.

Further, I/We agree that in case of forfeiture of Earnest Money or Performance Guarantee as aforesaid, I/We shall be debarred for participation in the re-bidding process of the work.

I/we undertake and confirm that eligible similar work(s) has/have not been got executed through another agency on back to back basis. Further that, if such a violation comes to the notice of Department, then I/we shall be debarred for bidding in MOHUA in future forever. Also, if such a violation comes to the notice of Department before date of start of work, the Competent Authority shall be free to forfeit the entire amount of Earnest Money Deposited/Performance Guarantee.

I/We hereby declare that I/We shall treat the bid documents drawings and other records connected with the work as secret/confidential documents and shall not communicate information/derived there from to any person other than a person to whom I/We am/are authorized to communicate the same or use the information in any manner prejudicial to the safety of the State.

Dated: **.....

Signature of Participating agency **

Witness: **

Address: **

Postal Address **

Occupation: **

[** to be filled by Participating agency]

ACCEPTANCE OF BID

The above bid (as modified by you as provided in the letters mentioned hereunder) is accepted by me for an on behalf of MoHUA for a sum of Rs.....*

(Rupee.....*.....
.....).

The letters referred to below shall form part of this contract agreement: -

- (a)
- (b)
- (c)

For & on behalf of MoHUA

Signature

Dated: Designation

CONTRACT CONDITIONS

A. DEFINITIONS

The Contract means the documents forming the bid and acceptance thereof and the formal agreement executed between the competent authority on behalf of Ministry of Housing & Urban Affairs (MoHUA), GoI and the selected agency, together with the documents referred to therein including these conditions, the specifications, designs, drawings and instructions issued from time to time by MoHUA and all these documents taken together, shall be deemed to form one contract and shall be complementary to one another.

- 1.1 Ministry of Housing & Urban Affairs, GoI, hereinafter called 'MoHUA' propose to get the works executed as mentioned in the Contract as Implementing /Executing Authority.
- 1.2 In the contract, the following expressions shall, unless the context otherwise requires, have the meanings, hereby respectively assigned to them: -
 - a) MoHUA shall mean Ministry of Housing & Urban Affairs, a Ministry of Government of India with its office at Nirman Bhawan, Maulana Azad Road, New Delhi or its Administrative officers or other employees authorized to deal with any matter with which these persons are concerned and authorized on its behalf.
 - b) COMPETENT AUTHORITY means the authorised representative declared by MoHUA who shall supervise and be in-charge of the work.
 - c) APPROVAL means approved in writing including subsequent written confirmation of previous verbal approval.
 - d) SCHEDULE OF QUANTITIES means the complete quantity statement forming or Schedule of Quantities forming part of the bid.
 - e) SELECTED AGENCY shall mean the individual, firm, LLP or company, whether incorporated or not, undertaking the works and shall include the legal personal representative of such individual or the persons composing such firm or LLP or company, or the successors of such firm or company and the permitted assignees of such individual, firm or company.
 - f) CONTRACT VALUE means the sum for which the bid is accepted as per the letter of Award.
 - g) DRAWINGS mean the drawings referred to in the contract document including modifications if any and such other drawings as may from time to time be furnished and/ or approved by MoHUA.
 - h) DATE OF COMMENCEMENT OF WORK: The date of start of contract shall be reckoned from the date of handing over of site and approvals.

- i) LANGUAGE: All documents and correspondence in respect of this contract shall be in English Language.
- j) "LETTER OF AWARD" shall mean MoHUA's letter or notification conveying its acceptance of the bid subject to such conditions as may have been stated therein.
- k) MONTH means English Calendar month 'Day' means a Calendar day of 24 Hrs each.
- l) OWNER/CLIENT means the MoHUA, Govt. of India who will be entering into the contract and getting the work executed.
- m) SITE means the lands and other places on, under, in or through which the works are to be executed or carried out and any other lands or places provided by MoHUA or used for the purpose of the contract.
- n) BID means the Selected agency's priced offer to MoHUA for the execution and completion of the work and the remedying of any defects therein in accordance with the provisions of the Contract, as accepted by the Letter of Award or Award letter. The word BID is synonymous with Bid and the word BID DOCUMENTS with "Bidding Documents" or "offer documents".
- o) WRITING means any manuscript typed, written or printed statement under or over signature and/or seal as the case may be.
- p) Works or Work shall unless there be something either in the subject or context repugnant to such construction, be construed and taken to mean the works by or by virtue of the contract contracted to be executed whether temporary or permanent, and whether original, altered, substituted or additional.
- q) Headings in the clauses/conditions of bid documents is for convenience only and shall not be used for interpretation of the clause/condition.
- r) Words imparting the singular meaning only also include the plurals and vice versa where the context requires. Words importing persons or parties shall include firms and corporations and organizations having legal capacities.
- s) Excepted Risk are risks due to riots (other than those on account of selected agency's employees), war (whether declared or not) invasion, act of foreign enemies, hostilities, civil war, rebellion revolution, insurrection, military or usurped power, any acts of Government, damages from aircraft, acts of God, such as earthquake, lightening and unprecedented floods, and other causes over which the selected agency has no control and accepted as such by the MoHUA.
- t) Market Rate shall be the rate as decided by the Competent Authority on the basis of the prevailing cost of materials and labour at the site where the work is to be executed plus the percentage mentioned elsewhere in the bid document to cover, all overheads and profits.

B. CLAUSES OF CONTRACT

1.0 Performance Guarantee

- (i) The selected agency shall submit an irrevocable Performance Guarantee of 5% (Five percent) of the contract amount in addition to other deposits mentioned elsewhere in the contract for his proper performance of the contract agreement, (not withstanding and/or without prejudice to any other provisions in the contract) within 15 (fifteen) days from the date of issue of letter of acceptance. This Performance guarantee shall be in the form of bank guarantee from any scheduled bank/ commercial bank. The Performance Bank Guarantee shall be initially valid for 18 months from the issuance of award of contract plus 60 days beyond that. In case the time for completion of work gets enlarged, the selected agency shall get the validity of Performance Bank Guarantee extended to cover such enlarged time for completion of work. After recording of the completion certificate for the work by the competent authority, the Performance Bank Guarantee shall be returned to the selected agency, without any interest.
- (ii) The Competent Authority shall not make a claim under the performance guarantee except for amounts to which MoHUA is entitled under the contract (not withstanding and/or without prejudice to any other provisions in the contract agreement) in the event of:
 - (a) Failure by the selected agency to extend the validity of the Performance Bank Guarantee as described herein above, in which event the Competent Authority may claim the full amount of the Performance Bank Guarantee.
 - (b) Failure by the selected agency to pay MoHUA any amount due, either as agreed by the selected agency or determined under any of the Clauses/Conditions of the agreement, within 30 days of the service of notice to this effect by Competent Authority.
 - (c) In the event of the contract being determined or rescinded under provision of any of the Clause/Condition of the agreement, the Performance Bank Guarantee shall stand forfeited in full and shall be absolutely at the disposal of MoHUA.
 - (d) On substantial Completion of any work which has been completed to such an extent that the intended purpose of the work is met and ready to use, then a provisional completion certificate shall be recorded by the Competent Authority. The provisional certificate shall have appended with a list of outstanding balance item of work that need to be completed in accordance with the provisions of the contract.

This provisional completion certificate shall be recorded by Competent Authority with the approval of MoHUA.

1A. Recovery of Security Deposit

The person/persons whose bid(s) may be accepted (hereinafter called the selected agency) shall permit MoHUA at the time of making any payment to selected agency for work done under the contract to deduct a sum at the rate of 5% of the gross amount of each running and final bill till the sum deducted will amount to security deposit of 5% of the contract value of the work. Such deductions will be made and held by Government by way of Security Deposit unless he/they has/have deposited the amount of Security at the rate mentioned above in the form of Government Securities or Fixed Deposit receipts. In case a Fixed Deposit receipt of any Bank is furnished by the selected agency to the Government as part of the Security Deposit and the Bank is unable to make payment against the said Fixed Deposit receipt, the loss caused thereby shall fall on the selected agency and the selected agency shall forthwith on demand furnish additional security to the Government to make good the deficit.

All compensations or the other sums of money payable by the selected agency under the terms of this contract may be deducted from, or paid by the sale of a sufficient part of his security deposit or from the interest arising there from, or from any sums which may be due to or may become due to the selected agency by Government on any account whatsoever and in the event of his Security Deposit being reduced by reason of any such deductions or sale as aforesaid, the selected agency shall within 10 days make good in cash or Fixed Deposit receipt bided by the State Bank of India or by scheduled Banks or Government Securities (if deposited for more than 12 months) endorsed in favour of the Competent Authority, any sum or sums which may have been deducted from, or raised by sale of his security deposit or any part thereof.

The Security Deposit shall be collected from the running bills and the final bill of the selected agency at the rates mentioned in the contract.

2.0 Compensation for Delay

If the selected agency fails to maintain the required progress or to complete the work and clear the site on or before the contract or justified extended date of completion, as per clause 5 (excluding any extension under Clause 5.5) as well as any extension granted under clauses 12 and 15, selected agency shall, without prejudice to any other right or remedy available under the law to the Government on account of such breach, pay as agreed compensation the amount calculated at the rates stipulated below as the authority MoHUA or their designee/representative may decide on the amount of Bided Value of the work for every completed day/month (as determined) that the progress remains below that specified in Clause 5 or that the work remains incomplete.

This will also apply to items or group of items for which a separate period of completion has been specified.

- (i) Compensation @ 1 % per month of delay
For delay of work to be computed on per day basis

Provided always that the total amount of compensation for delay to be paid under this Condition shall not exceed 10% of the contract value of work or of the contract value of the Sectional part of work for which a separate period of completion is originally given.

Provided that compensation during the progress of work before the justified extended date of completion for delay under this clause shall be for non-achievement of sectional completion or part handing over of work on stipulated/justified extended date for such part work or if delay affects any other works/services. This is without prejudice to right of action by the Competent Authority under clause 3 for delay in performance and claim of compensation under that clause.

In case action under clause 2 has not been finalized and the work has been determined under clause 3, the right of action under this clause shall remain post determination of contract but levy of compensation shall be for days the progress is behind the schedule on date of determination, as assessed by MoHUA or their designee/representative after due consideration of justified extension. The compensation for delay, if not decided before the determination of contract, shall be decided after of determination of contract.

The amount of compensation may be adjusted or set-off against any sum payable to the selected agency under this or any other contract with the Government. In case, the selected agency does not achieve a particular milestone mentioned in this document or the re-scheduled milestone(s) in terms of Clause 5.4, the amount shown against that milestone shall be withheld, to be adjusted against the compensation levied as above. With-holding of this amount on failure to achieve a milestone, shall be automatic without any notice to the selected agency. However, if the selected agency catches up with the progress of work on the subsequent milestone(s), the withheld amount shall be released. In case the selected agency fails to make up for the delay in subsequent milestone(s), amount mentioned against each milestone missed subsequently also shall be withheld. However, no interest, whatsoever, shall be payable on such withheld amount.

3.0 When Contract can be Determined

Subject to other provisions contained in this clause, the Competent Authority may, without prejudice to his any other rights or remedy against the selected agency in respect of any delay, inferior workmanship, any claims for damages and/or any other provisions of

this contract or otherwise, and whether the date of completion has or has not elapsed, by notice in writing absolutely determine the contract in any of the following cases:

- (i) If the selected agency having been given by the Competent Authority a notice in writing to rectify, reconstruct or replace any defective work or that the work is being performed in an inefficient or otherwise improper or poor workmanship shall omit to comply with the requirement of such notice for a period of seven days thereafter.
- (ii) If the selected agency has, without reasonable cause, suspended the progress of the work or has failed to proceed with the work with due diligence and continues to do so after a notice in writing of seven days from the Competent Authority.
- (iii) If the selected agency fails to complete the work or section of work with individual date of completion on or before the stipulated or justified extended date, on or before such date of completion; and the Competent Authority without any prejudice to any other right or remedy under any other provision in the contract has given further reasonable time in a notice given in writing in that behalf as either mutually agreed or in absence of such mutual agreement by his own assessment making such time essence of contract and in the opinion of Competent Authority the selected agency will be unable to complete the same or does not complete the same within the period specified.
- (iv) If the selected agency persistently neglects to carry out his obligations under the contract and/or commits default in complying with any of the terms and conditions of the contract and does not remedy it or take effective steps to remedy it within 7 days after a notice in writing is given to him in that behalf by the Competent Authority.
- (v) If the selected agency shall offer or give or agree to give to any person in Government service or to any other person on his behalf any gift or consideration of any kind as an inducement or reward for doing or forbearing to do or for having done or forborne to do any act in relation to the obtaining or execution of this or any other contract for Government.
- (vi) If the selected agency shall enter into a contract with Government in connection with which commission has been paid or agreed to be paid by him or to his knowledge, unless the particulars of any such commission and the terms of payment thereof have been previously disclosed in writing to the Competent Authority.
- (vii) If the selected agency had secured the contract with Government as a result of wrong bidding or other non-bonafide methods of competitive bidding or commits breach of Integrity Agreement.
- (viii) If the selected agency being an individual, or if a firm, any partner thereof shall at any time be adjudged insolvent or have a receiving

order or order for administration of his estate made against him or shall take any proceedings for liquidation or composition (other than a voluntary liquidation for the purpose of amalgamation or reconstruction) under any Insolvency Act for the time being in force or make any conveyance or assignment of his effects or composition or arrangement for the benefit of his creditors or purport so to do, or if any application be made under any Insolvency Act for the time being in force for the sequestration of his estate or if a trust deed be executed by him for benefit of his creditors.

- (ix) If the selected agency being a company shall pass a resolution or the court shall make an order that the company shall be wound up or if a receiver or a manager on behalf of a creditor shall be appointed or if circumstances shall arise which entitle the court or the creditor to appoint a receiver or a manager or which entitle the court to make a winding up order.
- (x) If the selected agency shall suffer an execution being levied on his goods and allow it to be continued for a period of 21 days.
- (xi) If the selected agency assigns, (excluding part(s) of work assigned to other agency(s) by the selected agency as per terms of contract), transfers, sublets (engagement of labour on a piece-work basis or of labour with materials not to be incorporated in the work, shall not be deemed to be subletting) or otherwise parts with or attempts to assign, transfer, sublet or otherwise parts with the entire works or any portion thereof without the prior written approval of the Competent Authority.
- (xii) When the selected agency has made himself liable for action under any of the cases aforesaid, the Competent Authority on behalf of the President of India shall have powers:
 - (a) To determine the contract as aforesaid so far as performance of work by the selected agency is concerned (of which determination notice in writing to the selected agency under the hand of the Competent Authority shall be conclusive evidence). Upon such determination, the Earnest Money Deposit, Security Deposit already recovered and Performance Guarantee under the contract shall be liable to be forfeited and shall be absolutely at the disposal of the Government.
 - (b) After giving notice to the selected agency to measure up the work of the selected agency and to take such whole, or the balance or part thereof, as shall be un-executed out of his hands and to give it to another participating agency to complete the work. The selected agency, whose contract is determined as above, shall not be allowed to participate in the bidding process for the balance work. In the event of above courses being adopted by the Competent Authority, the selected agency shall have no claim to compensation for any loss sustained by him by

reasons of his having purchased or procured any materials or entered into any engagements or made any advances on account or with a view to the execution of the work or the performance of the contract. And in case action is taken under any of the provision aforesaid, the selected agency shall not be entitled to recover or be paid any sum for any work thereof or actually performed under this contract unless and until the Competent Authority has certified in writing the performance of such work and the value payable in respect thereof and he shall only be entitled to be paid the value so certified.

4.0 Selected agency liable to pay Compensation even if action not taken under Clause 3

In any case in which any of the powers conferred upon the Competent Authority by Clause-3 thereof, shall have become exercisable and the same are not exercised, the non-exercise thereof shall not constitute a waiver of any of the conditions hereof and such powers shall notwithstanding be exercisable in the event of any future case of default by the selected agency and the liability of the selected agency for compensation shall remain unaffected. In the event of the Competent Authority putting in force all or any of the powers vested in him under the preceding clause he may, if he so desires after giving a notice in writing to the selected agency, take possession of (or at the sole discretion of the Competent Authority which shall be final and binding on the selected agency) use as on hire (the amount of the hire money being also in the final determination of the Competent Authority) all or any tools, plant, materials and stores, in or upon the works, or the site thereof belonging to the selected agency, or procured by the selected agency and intended to be used for the execution of the work/or any part thereof, paying or allowing for the same in account at the contract rates, or, in the case of these not being applicable, at current market rates to be certified by the Competent Authority, whose certificate thereof shall be final, and binding on the selected agency, clerk of the works, foreman or other authorized agent to remove such tools, plant, materials, or stores from the premises (within a time to be specified in such notice) and in the event of the selected agency failing to comply with any such requisition, the Competent Authority may remove them at the selected agency's expense or sell them by auction or private sale on account of the selected agency and his risk in all respects and the certificate of the Competent Authority as to the expenses of any such removal and the amount of the proceeds and expenses of any such sale shall be final and conclusive against the selected agency.

5.0 Time and Extension for Delay

The time allowed for execution of the Works or the extended time in accordance with these conditions shall be the essence of the Contract.

The execution of the works shall commence from such time period as mentioned in this document or from the date of handing over of the site notified by the Competent Authority, whichever is later. However, the handing over of site by the Competent Authority, in full or in part shall be completed within six months from issue of acceptance letter. If the selected agency commits default in commencing the execution of the work as aforesaid, the Performance Bank Guarantee shall be forfeited by the Competent Authority and shall be absolutely at the disposal of the Government without prejudice to any other right or remedy available in law. The time period for completion of the project will be extended with imposition of compensation for delay only.

5.1 As soon as possible but within twenty one days of award of work and statutory approvals in consideration of

a) Schedule of handing over of site

b) Schedule of issue of designs

(i) The selected agency shall submit a Time and Progress Chart for each mile stone. The Competent Authority may within 30 days thereafter, if required modify, and communicate the program approved to the selected agency failing which the program submitted by the selected agency shall be deemed to be approved by the Competent Authority. The work programme shall include all details of balance drawings and decisions required to complete the contract with specific dates by which these details are required by selected agency without causing any delay in execution of the work. The Chart shall be prepared in direct relation to the time stated in the contract documents for completion of items of the works. It shall indicate the forecast of the dates of commencement and completion of various trades of sections of the work and may be amended as necessary by agreement between the Competent Authority and the selected agency within the limitations of time imposed in the contract documents, and further to ensure good progress during the execution of the work, the selected agency shall in all cases in which the time allowed for any work, exceeds one month (save for special jobs for which a separate programme has been agreed upon) complete the work as per mile stones

(ii) In case of non-submission of construction programme by the selected agency the program approved by the Competent Authority shall be deemed to be final.

(iii) The approval by the Competent Authority of such programme shall not relieve the selected agency of any of the obligations under the contract.

(iv) The selected agency shall submit the time and progress chart and progress report using the mutually agreed software or in other format decided by Competent Authority for the work done during previous month to the Competent Authority on or before 5th day of each month.

5.2 If the work(s) be delayed by:-

- (i) Force majeure, or
- (ii) Abnormally bad weather, or
- (iii) Serious loss or damage by fire, or
- (iv) Civil commotion, local commotion of workmen, strike or lockout, affecting any of the trades employed on the work, or
- (v) Delay on the part of other selected agency or tradesmen engaged by Competent Authority in executing work not forming part of the contract, or
- (vi) Non-availability of stores, which are the responsibility of Government to supply or
- (vii) Non-availability or break down of tools and Plant to be supplied or supplied by Government or
- (viii) Any other cause like above which, in the reasoned opinion of the Competent Authority is beyond the selected agency's control.

Then upon the happening of any such event causing delay, the selected agency shall immediately give notice thereof in writing to the Competent Authority for entry in the hindrance register (physical or web-based but shall nevertheless use constantly his best endeavors to prevent or make good the delay and shall do all that may be reasonably required to the satisfaction of the Competent Authority to proceed with the works.

The selected agency shall have no claim of damages for extension of time granted or rescheduling of milestone/s for events listed in sub clause 5.2.

5.3 In case the work is hindered by any reasons, in the opinion of the

selected agency, by the Department or for someone for whose action the Department is responsible, the selected agency may immediately give notice thereof in writing to the Competent Authority in the same manner as prescribed under sub Clause 5.2 seeking extension of time or rescheduling of milestone/s. The authority as indicated in Memorandum shall, if justified, give a fair and reasonable extension of time and reschedule the mile stones for completion of work after due consideration of the same within 30 days of receipt of such request. In event of non application by the selected agency for extension of time Competent Authority after affording opportunity to the selected agency may give, supported with a programme, a fair and reasonable extension within a reasonable period of occurrence of the event.

Such extension of time or rescheduling of milestone/s shall be without prejudice to any other right or remedy of the parties in contract or in law; provided further that for concurrent delays under this sub clause and sub clause 5.2 to the extent the delay is covered under sub clause 5.2 the selected agency shall be entitled to only extension of time and no damages.

5.4 Request for rescheduling of mile stones or extension of time, to be eligible for consideration, shall be made by the selected agency in writing within fourteen days of the happening of the event causing delay on the prescribed forms to be made available by Competent Authority. The selected agency shall indicate in such a request the period by which rescheduling of milestone/s or extension of time is desired. With every request for rescheduling of milestones, or if at any time the actual progress of work falls behind the approved programme by more than 10% of the stipulated period of completion of contract, the selected agency shall produce a revised programme which shall include all details of pending drawings and decisions required to complete the contract and also the target dates by which these details should be available without causing any delay in execution of the work. A recovery as specified in memorandum shall be made on per day basis in case of delay in submission of the revised programme.

5.4.1 In any such case the authority as indicated in memorandum may give a fair and reasonable extension of time for completion of work or reschedule the mile stones. Such extension or rescheduling of the milestones shall be communicated to the selected agency by the authority as indicated in memorandum in writing, within 30 days of the date of receipt of such request from the selected agency in prescribed form. In event of non application by the selected agency for extension of time Competent Authority after affording opportunity to the selected agency may give, supported with a programme (as specified under 5.4 above), a fair and reasonable extension within a reasonable period of occurrence of the event.

5.5 In case the work is delayed by any reasons, in the opinion of the Competent Authority, by the selected agency for reasons beyond the events mentioned in clause 5.2 or clause 5.3 or clause 5.4 and beyond the justified extended date; without prejudice to right to take action under Clause 3, the Competent Authority may grant extension of time required for completion of work without rescheduling of milestones. The selected agency shall be liable for levy of compensation for delay for such extension of time.

6.0 Measurements of Work Done

Competent Authority shall, except as otherwise provided, ascertain and determine by measurement, the value in accordance with the contract of work done.

All measurement of all items having financial value shall be entered in Measurement Book (MB) and/or level field book so that a complete record is obtained of all works performed under the contract. All measurements and levels shall be taken jointly by the Competent Authority or his authorized representative and by the selected agency or

his authorized representative from time to time during the progress of the work and such measurements shall be signed and dated by the Competent Authority and the selected agency or their representatives in token of their acceptance. If the selected agency objects to any of the measurements recorded, a note shall be made to that effect with reason and signed by both the parties.

If for any reason the selected agency or his authorized representative is not available and the work of recording measurements is suspended by the Competent Authority, the Competent Authority and MoHUA shall not entertain any claim from selected agency for any loss or damages on this account. If the selected agency or his authorized representative does not remain present at the time of such measurements after the selected agency or his authorized representative has been given a notice in writing three (3) days in advance or fails to countersign or to record objection within a week from the date of the measurement, then such measurements recorded in his absence by the Competent Authority or his representative shall be deemed to be accepted by the selected agency. The selected agency shall, without extra charge, provide all assistance with every appliance, labour and other things necessary for measurements and recording levels. Except where any general or detailed description of the work expressly shows to the contrary, measurements shall be taken in accordance with the procedure set forth in the CPWD specifications notwithstanding any provision in the relevant standard method of measurement or any general or local custom. In the case of items which are not covered by CPWD specifications, measurements shall be taken in accordance with the relevant standard method of measurement issued by the Bureau of Indian Standards (BIS) and if for any item no such standard is available, then a mutually agreed method shall be followed.

The selected agency shall give, not less than seven days' notice to the Competent Authority or his authorized representative in charge of the work, before covering up or otherwise placing beyond the reach of measurement any work in order that the same may be measured and correct dimensions thereof be taken before the same is covered up or placed beyond the reach of measurement and shall not cover up and place beyond reach of measurement any work without consent in writing of the Competent Authority or his authorized representative in charge of the work who shall within the aforesaid period of seven days inspect the work, and if any work shall be covered up or placed beyond the reach of measurements without such notice having been given or the Competent Authority's consent being obtained in writing, the same shall be uncovered at the selected agency's expense, or in default thereof no payment or allowance shall be made for such work or the materials with which the same was executed. Competent Authority or his authorized representative may cause either themselves or through

another officer of the department to check the measurements recorded jointly or otherwise as aforesaid and all provisions stipulated herein above shall be applicable to such checking of measurements or levels.

It is also a term of this contract that recording of measurements of any item of work in the Measurement Book and/or its payment in the interim, on account or final bill shall not be considered as conclusive evidence as to the sufficiency of any work or material to which it relates nor shall it relieve the selected agency from liabilities from any over measurement or effects noticed till completion of the defects liability period.

6A Computerized Measurement Book

Competent Authority shall, except as otherwise provided, ascertain and determine by measurement the value of work done in accordance with the contract. All measurements of all items having financial value shall be entered by the selected agency and compiled in the shape of the Computerized Measurement Book having pages of A-4 size as per the format of the department so that a complete record is obtained of all the items of works performed under the contract. All such measurements and levels recorded by the selected agency or his authorized representative from time to time, during the progress of the work, shall be got checked by the selected agency from the Competent Authority or his authorized representative as per interval or program fixed in consultation with Competent Authority or his authorized representative. After the necessary corrections made by the Competent Authority, the measurement sheets shall be returned to the selected agency for incorporating the corrections and for resubmission to the Competent Authority for the dated signatures by the Competent Authority and the selected agency or their representatives in token of their acceptance.

Whenever bill is due for payment, the selected agency would initially submit draft computerized measurement sheets and these measurements would be got checked/test checked from the Competent Authority and/or his authorized representative. The selected agency will, thereafter, incorporate such changes as may be done during these checks/test checks in his draft computerized measurements, and submit to the department a computerized Measurement Book, duly bound, and with its pages machine numbered. The Competent Authority and/or his authorized representative would thereafter check this MB, and record the necessary certificates for their checks/test checks.

The final, fair, computerized measurement book given by the selected agency, duly bound, with its pages machine numbered, should be 100% correct, and no cutting or over-writing in the measurements would thereafter be allowed. If at all any error is noticed, the selected agency

shall have to submit a fresh Computerized MB with its pages duly machine numbered and bound, after getting the earlier MB cancelled by the department. The selected agency shall submit two spare copies of such Computerized MB's for the purpose of reference and record by the various officers of the department.

The selected agency shall also submit to the department separately his computerized Abstract of Cost and the bill based on these measurements, duly bound, and its pages machine numbered along with two spare copies of the "bill. Thereafter, this bill will be processed by the Division Office and allotted a number as per the computerized record in the same way as done for the Measurement Book meant for measurements.

The selected agency shall, without extra charge, provide all assistance with every appliance, labour and other things necessary for checking of measurements/levels by the Competent Authority or his representative.

Except where any general or detailed description of the work expressly shows to the contrary, measurements shall be taken in accordance with the procedure set forth in the specifications notwithstanding any provision in the relevant standard method of measurement or any general or local custom. In the case of items which are not covered by specifications, measurements shall be taken in accordance with the relevant standard method of measurement issued by the Bureau of Indian Standards (BIS) and if for any item no such standard is available then a mutually agreed method shall be followed.

The selected agency shall give not less than seven days' notice to the Competent Authority or his authorized representative in charge of the work before covering up or otherwise placing beyond the reach of checking and/or test checking the measurement of any work in order that the same may be checked and/or test checked and correct dimensions thereof be taken before the same is covered up or placed beyond the reach of checking and/or test checking measurement and shall not cover up and place beyond reach of measurement any work without consent in writing of the Competent Authority or his authorized representative in charge of the work who shall within the aforesaid period of seven days inspect the work, and if any work shall be covered up or placed beyond the reach of checking and/or test checking measurements without such notice having been given or the Competent Authority's consent being obtained in writing the same shall be uncovered at the selected agency's expense, or in default thereof no payment or allowance shall be made for such work or the materials with which the same was executed.

Competent Authority or his authorized representative may cause either themselves or through another officer of the department to check the measurements recorded by selected agency and all provisions stipulated

herein above shall be applicable to such checking of measurements or levels.

It is also a term of this contract that checking and/or test checking the measurements of any item of work in the Measurement Book and/or its payment in the interim, on account of final bill shall not be considered as conclusive evidence as to the sufficiency of any work or material to which it relates nor shall it relieve the selected agency from liabilities from any over measurement or defects noticed till completion of the defects liability period.

7.0 Payment on Intermediate Certificate to be regarded as advances

The interim or running account bills shall be submitted by the selected agency for the work executed on the basis of such recorded measurements on the format of the Department in triplicate on or before the date of every month fixed for the same by the Competent Authority. The selected agency shall not be entitled to be paid any such interim payment if the gross work done together with net payment/adjustment of advances for material collected, if any, since the last such payment is less than the amount specified in memorandum, in which case the interim bill shall be prepared on the appointed date of the month after the requisite progress is achieved. Competent Authority shall arrange to have the bill verified by taking or causing to be taken, where necessary, the requisite measurements of the work. In the event of the failure of the selected agency to submit the bills, no claims whatsoever due to delays on payment including that of interest shall be payable to the selected agency. Payment on account of amount admissible shall be made by the Competent Authority certifying the sum to which the selected agency is considered entitled by way of interim payment at such rates as decided by the Competent Authority. The amount admissible shall be paid by 15th working day after the day of presentation of the bill by the selected agency to the Competent Authority with the account of the material issued by the Department, or dismantled materials, if any. In case of delay in payment of intermediate bills after 45 days of submission of bill by the selected agency provided the bill submitted by the selected agency found to be in order, a simple interest @ 10% per annum shall be paid to the selected agency from the date of expiry of prescribed time limit which will be compounded on yearly basis.

All such interim payments shall be regarded as payment by way of advances against final payment only and shall not preclude the requiring of bad, unsound and imperfect or unskilled work to be rejected, removed, taken away and reconstructed or re-erected. Any certificate given by the Competent Authority relating to the work done or materials delivered forming part of such payment, may be modified or

corrected by any subsequent such certificate(s) or by the final certificate and shall not by itself be conclusive evidence that any work or materials to which it relates is/are in accordance with the contract and specifications. Any such interim payment, or any part thereof shall not in any respect conclude, determine or affect in any way powers of the Competent Authority under the contract or any of such payments be treated as final settlement and adjustment of accounts or in any way vary or affect the contract.

Pending consideration of extension of date of completion, interim payments shall continue to be made as herein provided without prejudice to the right of the department to take action under the terms of this contract for delay in the completion of work, if the extension of date of completion is not granted by the competent authority.

The Competent Authority in his sole discretion on the basis of a certificate from authorized officer by MoHUA to the effect that the work has been completed up to the level in question make interim advance payments without detailed measurements for work done (other than foundations, items to be covered under finishing items) up to lintel level (including sunshade etc.) and slab level, for each floor working out at 75% of the assessed value. The advance payments so allowed shall be adjusted in the subsequent interim bill to be submitted by the selected agency within 10 days of the interim payment. In case of delay in submission of bill by the selected agency a simple interest @ 10% per annum shall be paid to the Government from the date of expiry of prescribed time limit which will be compounded on yearly basis.

8.0 Completion Certificate and Completion Plans

Within ten days of the completion of the work, the selected agency shall give notice of such completion to the Competent Authority and within thirty days of the receipt of such notice, the Competent Authority shall inspect the work and if there is no defect in the work, shall furnish the selected agency with a final certificate of completion, otherwise a provisional certificate of physical completion indicating defects (a) To be rectified by the selected agency and/or (b) For which payment will be made at reduced rates, shall be issued. But no final certificate of completion shall be issued, nor shall the work be considered to be complete until the selected agency shall have removed from the premises on which the work shall be executed all scaffolding, surplus materials, rubbish and all huts and sanitary arrangements required for his/their work people on the site in connection with the execution of the works as shall have been erected or constructed by the selected agency(s) and cleaned off the dirt from all wood work, doors, windows, walls, floor or other parts of the building, in, upon, or about which the work is to be executed or of which he may have had possession for the purpose of the execution; thereof, and not until the work shall have

been measured by the Competent Authority. If the selected agency shall fail to comply with the requirements of this Clause as to removal of scaffolding, surplus materials and rubbish and all huts and sanitary arrangements as aforesaid and cleaning off dirt on or before the date fixed for the completion of work, the Competent Authority may at the expense of the selected agency remove such scaffolding, surplus materials and rubbish etc., and dispose of the same as he thinks fit and clean off such dirt as aforesaid, and the selected agency shall have no claim in respect of scaffolding or surplus materials as aforesaid except for any sum actually realized by the sale thereof.

8A Completion Plans to be submitted by the selected agency

The selected agency shall submit completion plan as required vide CPWD General Specifications for Electrical works (Part-I internal) 2013 and (Part-II External) 1994 as amended up to date as applicable within thirty days of the completion of the work.

In case, the selected agency fails to submit the completion plan as aforesaid, he shall be liable to pay a sum of 0.1 % of Bided Value. The selected agency shall submit completion plan for Internal and External Civil, Electrical and Mechanical services within thirty days of the completion of the work, provided that the service plans having been issued for execution by the Competent Authority, unless the selected agency, by virtue of any other provision in the contract, is required to prepare such plans.

9.0 Payment of Final Bill

The final bill shall be submitted by the selected agency in the same manner as specified in interim bills within three months of physical completion of the work or within one month of the date of the final certificate of completion furnished by the Competent Authority whichever is earlier. No further claims shall be made by the selected agency after submission of the final bill and these shall be deemed to have been waived and extinguished. Payments of those items of the bill in respect of which there is no dispute and of items in dispute, for quantities and rates as approved by Competent Authority, will, as far as possible be made within six months, the period being reckoned from the date of receipt of the bill by the Competent Authority, complete with account of materials issued by the Department and dismantled materials.

9A Payment of Selected agency's Bills to Banks

Payments payable to selected agency may, if so desired by him, be made to agency's bank account.

10. Materials to be provided by the selected agency

The selected agency shall, at his own expense, provide all materials, required for the works other than those which are stipulated to be supplied by the Government.

The selected agency shall, at his own expense and without delay, supply to the Competent Authority samples of materials to be used on the work and shall get these approved in advance. All such materials to be provided by the selected agency shall be in conformity with the technical specifications as referred in the contract or CPWD specifications wherever applicable. The selected agency shall, if requested by the Competent Authority furnish proof, to the satisfaction of the Competent Authority that the materials so comply. The Competent Authority shall within thirty days of supply of samples or within such further period as he may require intimate to the selected agency in writing whether samples are approved by him or not. If samples are not approved, the selected agency shall forthwith arrange to supply to the Competent Authority for his approval, fresh samples complying with the specifications laid down in the contract. When materials are required to be tested in accordance with specifications, approval of the Competent Authority shall be issued after the test results are received.

The selected agency shall at his risk and cost submit the samples of materials to be tested or analyzed and shall not make use of or incorporate in the work any materials represented by the samples until the required tests or analysis have been made and materials finally accepted by the Competent Authority. The selected agency shall not be eligible for any claim or compensation either arising out of any delay in the work or due to any corrective measures required to be taken on account of and as a result of testing of materials.

The selected agency shall, at his risk and cost, make all arrangements and shall provide all facilities as the Competent Authority may require for collecting, and preparing the required number of samples for such tests at such time and to such place or places as may be directed by the Competent Authority and bear all charges and cost of testing unless specifically provided for otherwise elsewhere in the contract or specifications. The Competent Authority or his authorized representative shall at all times have access to the works and to all workshops and places where work is being prepared or from where materials, manufactured articles or machinery are being obtained for the works and the selected agency shall afford every facility and every assistance in obtaining the right to such access.

The Competent Authority shall have full powers to require the removal from the premises of all materials which in his opinion are not in accordance with the specifications and in case of default, the Competent Authority shall be at liberty to employ at the expense of the

selected agency, other persons to remove the same without being answerable or accountable for any loss or damage that may happen or arise to such materials. The Competent Authority shall also have full powers to require other proper materials to be substituted thereof and in case of default, the Competent Authority may cause the same to be supplied and all costs which may attend such removal and substitution shall be borne by the selected agency.

The selected agency shall at his own expense, provide a material testing lab at the site for conducting routine field tests. The lab shall be equipped at least with the testing equipment as specified in ANNEXURE-VI.

11.0 Work to be executed in Accordance with Specifications, Drawings and Orders etc.

The selected agency shall execute the whole and every part of the work in the most substantial and workmanlike manner both as regards materials and otherwise in every respect in strict accordance with the specifications. The selected agency shall also conform exactly, fully and faithfully to the design, drawings and instructions in writing in respect of the work signed by the Competent Authority and the selected agency shall be furnished free of charge one copy of the contract documents together with specifications, designs, drawings and instructions as are not included in the standard specifications of Central Public Works Department specified in memorandum or in any Bureau of Indian Standard (BIS) or any other, published standard or code or,

Schedule of Rates (SoR) or any other printed publication referred to elsewhere in the contract. The selected agency shall comply with the provisions of the contract and with the care and diligence execute and maintain the works and provide all labour and materials, tools and plants including for measurements and supervision of all works, structural plans and other things of temporary or permanent nature required for such execution and maintenance in so far as the necessity for providing these, is specified or is reasonably inferred from the contract. The selected agency shall take full responsibility for adequacy, suitability and safety of all the works and methods of construction.

12.0 Deviations/ Variations Extent and Pricing

The MoHUA reserves the Right to:

- (i) make alteration in, omissions from, additions to, for the original specifications, drawings, designs and instructions that may appear to him to be necessary or advisable during the progress of the work, and
- (ii) omit a part of the works in case of non-availability of a portion of the site or for any other reasons and the selected agency shall be bound to carry out the works in accordance with any instructions given to him in writing signed by the Competent Authority and

such alterations, omissions, additions or substitutions shall form part of the contract as if originally provided therein and any altered, additional or substituted work which the selected agency may be directed to do in the manner specified above as part of the works, shall be carried out by the selected agency on the same conditions in all respects including price on which he agreed to do the main work except as hereafter provided.

12.1 Extra Items & Substituted Item and Pricing

No extra Item will be entertained

13.0 Foreclosure of contract due to Abandonment or Reduction in Scope of Work

If at any time after acceptance of the bid or during the progress of work, the purpose or object for which the work is being done changes due to any supervening cause and as a result of which the work has to be abandoned or reduced in scope the Competent Authority shall give notice in writing to that effect to the selected agency stating the decision as well as the cause for such decision and the selected agency shall act accordingly in the matter. The selected agency shall have no claim to any payment of compensation or otherwise whatsoever, on account of any profit or advantage which he might have derived from the execution of the works in full but which he did not derive in consequence of the foreclosure of the whole or part of the works.

- (i) The selected agency shall be paid at contract rates, full amount for works executed at site and, in addition, a reasonable amount as certified by the Competent Authority for the items hereunder mentioned which could not be utilized on the work to the full extent in view of the foreclosure, any expenditure incurred on preliminary site work, e.g. temporary access roads, temporary labour huts, staff quarters and site office, storage accommodation and water storage tanks.
- (ii) Government shall have the option to take over selected agency's materials or any part thereof either brought to site or of which the selected agency is legally bound to accept delivery from suppliers (for incorporation in or incidental to the work) provided, however Government shall be bound to take over the materials or such portions thereof as the selected agency does not desire to retain. For materials taken over or to be taken over by Government, cost of such materials as detailed by Competent Authority shall be paid. The cost shall, however, take into account purchase price, cost of transportation and deterioration or damage which may have been caused to materials whilst in the custody of the selected agency.
- (iii) If any materials supplied by Government are rendered surplus, the same except normal wastage shall be returned by the selected agency to Government at rates not exceeding those at which these

were originally issued, less allowance for any deterioration or damage which may have been caused whilst the materials were in the custody of the selected agency.

In addition, cost of transporting such materials from site to Government stores, if so required by Government, shall be paid.

- (iv) Reasonable compensation for transfer of T&P from site to selected agency's permanent stores or to his other works, whichever is less. If T&P are not transported to either of the said places, no cost of transportation shall be payable.
- (v) Reasonable compensation for repatriation of selected agency's site staff and imported labour to the extent necessary.
- (vi) The selected agency shall, if required by the Competent Authority, furnish to him, books of account, wage books, time sheets and other relevant documents and evidence as may be necessary to enable him to certify the reasonable amount payable under this condition.

The reasonable amount of items on (i), (iv) and (v) above shall not be in excess of 2% of the cost of the work remaining incomplete on the date of closure, i.e. total stipulated cost of the work as per accepted bid less the cost of work actually executed under the contract and less the cost of selected agency's materials at site taken over by the Government as per item (ii) above. Provided always that against any payments due to the selected agency on this account or otherwise, the Competent Authority shall be entitled to recover or be credited with any outstanding balances due from the selected agency for advance paid in respect of any tool, plants and materials and any other sums which at the date of termination were recoverable by the Government from the selected agency under the terms of the contract.

In the event of action being taken under Clause 13 to reduce the scope of work, the selected agency may furnish fresh Performance Bank Guarantee on the same conditions, in the same manner and at the same rate for the balance bided amount and initially valid up to the extended date of completion or stipulated date of completion if no extension has been granted plus 60 days beyond that. Wherever such a fresh Performance Bank Guarantee is furnished by the selected agency the Competent Authority may return the previous Performance Bank Guarantee.

14.0 Carrying out part work at risk & cost of selected agency

If selected agency:

- (i) At any time makes default during currency of work or does not execute any part of the work with due diligence and continues to do so even after a notice in writing of 7 days in this respect from the Competent Authority; or
- (ii) Commits default in complying with any of the terms and conditions of the contract and does not remedy it or takes effective steps to

remedy it within 7 days even after a notice in writing is given in that behalf by the Competent Authority, or

Fails to complete the work(s) or items of work with individual dates of completion, on or before the date(s) so determined, and does not complete them within the period specified in the notice given in writing in that behalf by the Competent Authority.

The Competent Authority without invoking action under clause 3 may, without prejudice to any other right or remedy against the selected agency which have either accrued or accrue thereafter to Government, by a notice in writing to take the part work/part incomplete work of any item(s) out of his hands and shall have powers to:

- (a) Take possession of the site and any materials, constructional plant, implements, stores, etc., thereon; and/or
- (b) Carry out the part work/part incomplete work of any item(s) by any means at the risk and cost of the selected agency.

The Competent Authority shall determine the amount, if any, is recoverable from the selected agency for completion of the part work/ part incomplete work of any item(s) taken out of his hands and execute at the risk and cost of the selected agency, the liability of selected agency on account of loss or damage suffered by Government because of action under this clause shall not exceed 10% of the bided value of the work.

In determining the amount, credit shall be given to the selected agency with the value of work done in all respect in the same manner and at the same rate as if it had been carried out by the original selected agency under the terms of his contract, the value of selected agency's materials taken over and incorporated in the work and use of plant and machinery belonging to the selected agency.

The certificate of the Competent Authority as to the value of work done shall be final and conclusive against the selected agency provided always that action under this clause shall only be taken after giving notice in writing to the selected agency. Provided also that if the expenses incurred by the department are less than the amount payable to the selected agency at his agreement rates, the difference shall not be payable to the selected agency.

Any excess expenditure incurred or to be incurred by Government in completing the part work/part incomplete work of any item(s) or the excess loss of damages suffered or may be suffered by Government as aforesaid after allowing such credit shall without prejudice to any other right or remedy available to Government in law or per as agreement be recovered from any money due to the selected agency on any account, and if such money is insufficient, the selected agency shall be called upon in writing and shall be liable to pay the same within 30 days.

If the selected agency fails to pay the required sum within the aforesaid period of 30 days, the Competent Authority shall have the right to sell any or all of the selected agency's unused materials, constructional plant, implements, temporary building at site etc. and adjust the proceeds of sale thereof towards the dues recoverable from the selected agency under the contract and if thereafter there remains any balance outstanding, it shall be recovered in accordance with the provisions of the contract.

In the event of above course being adopted by the Competent Authority, the selected agency shall have no claim to compensation for any loss sustained by him by reason of his having purchased or procured any materials or entered into any engagements or made any advance on any account or with a view to the execution of the work or the performance of the contract.

15.0 Suspension of Work

- (i) The selected agency shall, on receipt of the order in writing of the Competent Authority, (whose decision shall be final and binding on the selected agency) suspend the progress of the works or any part thereof for such time and in such manner as the Competent Authority may consider necessary so as not to cause any damage or injury to the work already done or endanger the safety thereof for any of the following reasons:
 - a) On account of any default on the part of the selected agency or;
 - b) For proper execution of the works or part thereof for reasons other than the default of the selected agency; or
 - c) For safety of the works or part thereof.

The selected agency shall, during such suspension, properly protect and secure the works to the extent necessary and carry out the instructions given in that behalf by the Competent Authority.

- (ii) If the suspension is ordered for reasons (b) and (c) in sub-para (i) above:
 - a) The selected agency shall be entitled to an extension of time equal to the period of every such suspension plus 25%, for completion of the item or group of items of work for which a separate period of completion is specified in the contract and of which the suspended work forms a part, and;
 - b) If the total period of all such suspensions in respect of an item or group of items or work for which a separate period of completion is specified in the contract exceeds thirty days, the selected agency shall, in addition, be entitled to such compensation as the Competent Authority may consider reasonable in respect of salaries and/or wages paid by the selected agency to his employees and labour at site, remaining idle during the period of

suspension, adding thereto 2% to cover indirect expenses of the selected agency provided the selected agency submits his claim supported by details to the Competent Authority within 15 days of the expiry of the period of 30 days.

- (iii) If the works or part thereof is suspended on the orders of the Competent Authority for more than three months at a time, except when suspension is ordered for reason (a) in sub para (i) above, the selected agency may after receipt of such order serve a written notice on the Competent Authority requiring permission within fifteen days from receipt by the Competent Authority of the said notice, to proceed with the work or part thereof in regard to which progress has been suspended and if such permission is not granted within that time, the selected agency, if he intends to treat the suspension, where it affects only a part of the works as an omission of such part by Government or where it affects whole of the works, as an abandonment of the works by Government, shall within ten days of expiry of such period of 15 days give notice in writing of his intention to the Competent Authority. In the event of the selected agency treating the suspension as an abandonment of the contract by Government, he shall have no claim to payment of any compensation on account of any profit or advantage which he might have derived from the execution of the work in full but which he could not derive in consequence of the abandonment. He shall, however, be entitled to such compensation, as the Competent Authority may consider reasonable, in respect of salaries and/or wages paid by him to his employees and labour at site, remaining idle in consequence adding to the total thereof 2% to cover indirect expenses of the selected agency provided the selected agency submits his claim supported by details to the Competent Authority within 30 days of the expiry of the period of 3 months.

16.0 Action in case Work not done as per Specifications

All works under or in course of execution or executed in pursuance of the contract, shall at all times be open and accessible to the inspection and supervision of the Competent Authority, his authorized subordinates in charge of the work and all the superior officers, officers responsible for Quality Assurance Unit or any organization engaged by the Competent Authority for Quality Assurance and the selected agency shall, at all times, during the usual working hours and at all other times at which reasonable notice of the visit of such officers has been given to the selected agency, either himself be present to receive orders and instructions or have a responsible agent duly accredited in writing, present for that purpose.

Orders given to the selected agency's agent shall be considered to have the same force as if they had been given to the selected agency himself.

If it shall appear to the Competent Authority or his authorized subordinates in charge of the work or to the In-charge of Quality Assurance or his subordinate officers or the officers of the organization engaged by the Department for Quality Assurance or his subordinate officers, that any work has been executed with unsound, imperfect, or unskillful workmanship, or with materials or articles provided by him for the execution of the work which are unsound or of a quality inferior to that contracted or otherwise not in accordance with the contract, the selected agency shall, on demand in writing which shall be made within twelve months (six months in the case of work costing Rs. 10 Lakh and below except road work) of the completion of the work from the Competent Authority specifying the work, materials or articles complained of notwithstanding that the same may have been passed, certified and paid for forthwith rectify, or remove and reconstruct the work so specified in whole or in part, as the case may require or as the case may be, remove the materials or articles so specified and provide other proper and suitable materials or articles at his own charge and cost. In the event of the failing to do so within a period specified by the Competent Authority in his demand aforesaid, then the selected agency shall be liable to pay compensation at the same rate as under clause 2 of the contract (for non-completion of the work in time) for this default.

In such case the Competent Authority may not accept the particular item of work. The Competent Authority may accept such work/s at reduced rates as considered reasonable during the preparation of on account bills or final bill if the item is so acceptable without detriment to the safety and utility of the item and the structure or he may reject the work outright without any payment and/or get it and other connected and incidental items rectified, or removed and re-executed at the risk and cost of the selected agency.

Decision of the Competent Authority to be conveyed in writing in respect of the same will be final and binding on the selected agency.

17.0 Selected agency Liable for Damages, defects during defect liability period

If the selected agency or his working people or servants shall break, deface, injure or destroy any part of building in which they may be working, or any building, road, road kerb, fence, enclosure, water pipe, cables, drains, electric or telephone post or wires, trees, grass or grassland, or cultivated ground contiguous to the premises on which the work or any part is being executed, or if any damage shall happen to the work while in progress, from any cause whatever or if any defect, shrinkage or other faults appear in the work within twelve months (six months in the case of work costing Rs. Ten lakh and below except road work) after a certificate final or otherwise of its completion shall have been given by the Competent Authority as aforesaid arising out of defect

or improper materials or workmanship the selected agency shall upon receipt of a notice in writing on that behalf make the same good at his own expense or in default the Competent Authority cause the same to be made good by other workmen and deduct the expense from any sums that may be due or at any time thereafter may become due to the selected agency, or from his security deposit or the proceeds of sale thereof or of a sufficient portion thereof. The Security Deposit of the selected agency shall be refunded after completion of defect liability period.

18.0 Selected agency to Supply Tools & Plants etc.

The selected agency shall provide at his own cost all materials (except such special materials, if any, as may in accordance with the contract be supplied from the Competent Authority's stores), machinery, tools & plants as specified in ANNEXURE-VIII in addition to this, appliances, implements, other plants, ladders, cordage, tackle, scaffolding and temporary works required for the proper execution of the work, whether original, altered or substituted and whether included in the specifications or other documents forming part of the contract or referred to in these conditions or not, or which may be necessary for the purpose of satisfying or complying with the requirements of the Competent Authority as to any matter as to which under these conditions he is entitled to be satisfied, or which he is entitled to require together with carriage therefore to and from the work. The selected agency shall also supply without charge the requisite number of persons with the means and materials, necessary for the purpose of setting out works, and counting, weighing and assisting the measurement for examination at any time and from time to time of the work or materials. Failing his so doing, the same may be provided by the Competent Authority at the expense of the selected agency and the expenses may be deducted, from any money due to the selected agency, under this contract or otherwise and/or from his security deposit or the proceeds of sale thereof, or of a sufficient portions thereof.

18A Recovery of Compensation paid to Workmen

In every case in which by virtue of the provisions sub-section (1) of Section 12, of the Workmen's Compensation Act, 1923, Government is obliged to pay compensation to a workman employed by the selected agency, in execution of the works, Government will recover from the selected agency, the amount of the compensation so paid; and, without prejudice to the rights of the Government under sub-section (2) of Section 12, of the said Act, Government shall be at liberty to recover such amount or any part thereof by deducting it from the security deposit or from any sum due by Government to the selected agency whether under this contract or otherwise. Government shall not be bound to contest any claim made against it under sub-section (1) of

Section 12, of the said Act, except on the written request of the selected agency and upon his giving to Government full security for all costs for which Government might become liable in consequence of contesting such claim.

18B Ensuring Payment and Amenities to Workers if selected agency fails

In every case in which by virtue of the provisions of the Contract Labour (Regulation and Abolition) Act, 1970, and of the Contract Labour (Regulation and Abolition) Central Rules, 1971, Government is obliged to pay any amounts of wages to a workman employed by the selected agency in execution of the works, or to incur any expenditure in providing welfare and health amenities required to be provided under the above said Act and the rules under Clause 19H or under the C.P.W.D. selected agency's Labour Regulations, or under the Rules framed by Government from time to time for the protection of health and sanitary arrangements for workers employed by C.P.W.D. selected agency, Government will recover from the selected agency, the amount of wages so paid or the amount of expenditure so incurred; and without prejudice to the rights of the Government under sub-section(2) of Section 20, and sub-section (4) of Section 21, of the contract labour (Regulation and Abolition) Act, 1970, Government shall be at liberty to recover such amount or any part thereof by deducting it from the Security Deposit or from any sum due by Government to the selected agency whether under this contract or otherwise Government shall not be bound to contest any claim made against it under sub-section (1) of Section 20, sub-section (4) of Section 21, of the said Act, except on the written request of the selected agency and upon his giving to the Government full security for all costs for which Government might become liable in contesting such claim.

19. Labour Laws to be complied by the selected agency

The selected agency shall obtain a valid license under the Contract Labour (R&A) Act, 1970, and the Contract Labour (Regulation and Abolition) Central Rules, 1971, before the commencement of the work, and continue to have a valid license until the completion of the work. **The selected agency shall also comply with provisions of the Inter-State Migrant Workmen (Regulation of Employment and Conditions of Service) Act, 1979.**

The selected agency shall also abide by the provisions of the Child Labour (Prohibition and Regulation) Act, 1986.

The selected agency shall also comply with the provisions of the building and other Construction Workers (Regulation of Employment & Conditions of Service) Act, 1996 and the building and other Construction Workers Welfare Cess Act, 1996.

Any failure to fulfill these requirements shall attract the penal provisions of this contract arising out of the resultant non-execution of the work. No labour below the age of fourteen years shall be employed on the work. The ESI and EPF contributions on the part of MoHUA in respect of this contract shall be paid by the agency which shall not be reimbursed. The agency shall keep and maintain records pertaining to engaging labour, wages paid and their perks in prescribed Performa as approved by Competent Authority.

20. Minimum Wages Act to be complied with

The selected agency shall comply with all the provisions of the Minimum Wages Act, 1948, and Contract Labour (Regulation and Abolition) Act, 1970, amended from time to time and rules framed there under and other labour laws affecting contract labour that may be brought into force from time to time.

21. Work not to be sublet. Action in case of insolvency

The contract shall not be assigned or sublet without the written approval of the Competent Authority. And if the selected agency shall assign or sublet his contract, or attempt to do so, or become insolvent or commence any insolvency proceedings or make any composition with his creditors or attempt to do so, or if any bribe, gratuity, gift, loan, perquisite, reward or advantage pecuniary or otherwise, shall either directly or indirectly, be given, promised or offered by the participating agency, or any of his servants or agent to any public officer or person in the employ of Government in any way relating to his office or employment, or if any such officer or person shall become in any way directly or indirectly interested in the contract, the Competent Authority on behalf of the President of India shall have power to adopt the course specified in Clause 3 hereof in the interest of Government and in the event of such course being adopted, the consequences specified in the said Clause 3 shall ensue.

22. Compensation

All sums payable by way of compensation under any of these conditions shall be considered as reasonable compensation to be applied to the use of Government without reference to the actual loss or damage sustained and whether or not any damage shall have been sustained.

23. Changes in firm's Constitution to be intimated

Where the selected agency is a partnership firm, the previous approval in writing of the Competent Authority shall be obtained before any change is made in the constitution of the firm. Where the selected agency is an individual or a Hindu undivided family business concern, such approval as aforesaid shall likewise be obtained before the selected agency enters into any partnership agreement where under the

partnership firm would have the right to carry out the works hereby undertaken by the selected agency. If previous approval as aforesaid is not obtained, the contract shall be deemed to have been assigned in contravention of Clause 21 hereof and the same action may be taken, and the same consequences shall ensue as provided in the said Clause 21.

- 24.** All works to be executed under the contract shall be executed under the direction and subject to the approval in all respects of the Competent Authority who shall be entitled to direct at what point or points and in what manner they are to be commenced, and from time to time carried on.

25. Settlement of Disputes & Arbitration

Except where otherwise provided in the contract, all disputes and claims relating to the meaning of the specifications, designs, drawings and instructions here-in-before mentioned and as to the quality of workmanship or materials used in the work or as to any other question, claim, right, matter or thing whatsoever in any way arising out of or relating to the contract, designs, drawings, specifications, estimates, instructions, orders or these conditions or otherwise concerning the work or the execution or failure to execute the same whether arising during the progress of the work or after the cancellation, termination, completion or abandonment thereof shall be dealt with as mentioned here-in-after.

If the agency considers any work demanded of him to be outside the requirements of the contract, or disputes any drawings, record or decision given in writing by the Competent Authority on any matter in connection with or arising out of the contract or carrying out of the work to be unacceptable, he shall promptly within 15 days request MoHUA or their designee/representative in writing for written instructions or decision. Thereupon, he shall give his written instructions or decision within a period of one month from the receipt of the agency's letter. If he fails to give his decision within the aforesaid period, or if any party is dissatisfied with the decision of MoHUA, then either party may within a period of 30 days from the receipt of the decision of MoHUA or from the last date prescribed above for the MoHUA to give his decision if he delays or fails to give his decision, give notice to MoHUA for appointment of an arbitral tribunal, failing which the said decision shall be final, binding and conclusive, and not referable to adjudication by arbitration. It is a term of contract that each party invoking arbitration must exhaust the aforesaid mechanism of settlement of disputes prior to invoking arbitration.

Except where the decision has become final, binding and conclusive in terms of sub-para (i) above, disputes shall be referred for adjudication through arbitration by an arbitral tribunal.

The arbitral tribunal shall consist of three arbitrators chosen from a panel of seven arbitrators prepared by MoHUA. The panel will comprise of engineers retired from any government service from a position not below the level of Joint Secretary to the Government of India and having experience in the field of arbitration in construction contracts.

The MoHUA shall within 30 days from the receipt of a request on prescribed proforma from either party for appointment of arbitral tribunal, shall appoint one arbitrator from the panel of seven arbitrators, while the second arbitrator shall be chosen by the agency. If agency fails to choose one arbitrator within ten days then the second arbitrator shall also be appointed by MoHUA. The two appointed arbitrators shall appoint the third arbitrator from the same panel, who shall act as the presiding arbitrator.

It is a term of this contract that the party invoking arbitration shall give a list of disputes with amounts claimed in respect of each such dispute along with the notice for appointment of arbitrator and giving reference to the rejection by the MoHUA.

The arbitration shall be conducted in accordance with the provisions of the Arbitration and Conciliation Act, 1996 (26 of 1996) or any statutory modifications or re-enactment thereof and the rules made there under and for the time being in force shall apply to the arbitration proceeding under this clause.

It is also a term of this contract that the arbitral tribunal shall adjudicate on only such disputes as are referred to it by the appointing authority and give separate award against each dispute and claim referred to it and, in all cases, where the total amount of the claims by any party exceeds Rs 1,00,000/- the arbitral tribunal shall give reasons for the award.

The fees of the arbitral tribunal and the manner of its payment shall be determined by the arbitral tribunal after taking into consideration the rates specified in the Fourth Schedule of the Arbitration and Conciliation Act, 1996 as amended by the Amendment Act, 2015 or as per guidelines issued by the competent authority or ruling of Delhi High Court /Supreme Court of India.

26. Participating agency to indemnify Govt. Against Patent Rights

The selected agency shall fully indemnify and keep indemnified the President of India against any action, claim or proceeding relating to infringement or use of any patent or design or any alleged patent or design rights and shall pay any royalties which may be payable in respect of any article or part thereof included in the contract. In the

event of any claims made under or action brought against Government in respect of any such matters as aforesaid, the selected agency shall be immediately notified thereof and the selected agency shall be at liberty, at his own expense, to settle any dispute or to conduct any litigation that may arise there from, provided that the selected agency shall not be liable to indemnify the President of India if the infringement of the patent or design or any alleged patent or design right is the direct result of an order passed by the Competent Authority in this behalf.

27. Action where no Specifications are specified

In the case of any class of work for which there is no such specifications as referred to in Clause 11, such work shall be carried out in accordance with the Bureau of Indian Standards Specifications. In case, there are no such specifications in Bureau of Indian Standards, the work shall be carried out as per manufacturers' specifications, if not available then as per local/District Specifications. In case there are no such specifications as required above, the work shall be carried out in all respects in accordance with the instructions and requirements of the Competent Authority.

28. Withholding and lien in respect of sum due from selected agency

(i) Whenever any claim or claims for payment of a sum of money arises out of or under the contract or against the selected agency, the Competent Authority or the Government shall be entitled to withhold and also have a lien to retain such sum or sums in whole or in part from the security, if any deposited by the selected agency and for the purpose aforesaid, the Competent Authority or the Government shall be entitled to withhold the security deposit, if any, furnished as the case may be and also have a lien over the same pending finalization or adjudication of any such claim. In the event of the security being insufficient to cover the claimed amount or amounts or if no security has been taken from the selected agency, the Competent Authority or the Government shall be entitled to withhold and have a lien to retain to the extent of such claimed amount or amounts referred to above, from any sum or sums found payable or which may at any time thereafter become payable to the selected agency under the same contract or any other contract with the Competent Authority of the Government or any contracting person through the Competent Authority pending finalization of adjudication of any such claim. It is an agreed term of the contract that the sum of money or moneys so withheld or retained under the lien referred to above by the Competent Authority or Government will be kept withheld or retained as such by the Competent Authority or Government till the claim arising out of or under the contract is determined by the arbitrator(if the contract is governed by the arbitration clause) by the competent court, as the case may be and that the selected agency

will have no claim for interest or damages whatsoever on any account in respect of such withholding or retention under the lien referred to above and duly notified as such to the selected agency. For the purpose of this clause, where the selected agency is a partnership firm or a limited company, the Competent Authority or the Government shall be entitled to withhold and also have a lien to retain towards such claimed amount or amounts in whole or in part from any sum found payable to any partner/limited company as the case may be, whether in his individual capacity or otherwise.

- (ii) Government shall have the right to cause an audit and technical examination of the works and the final bills of the selected agency including all supporting vouchers, abstract, etc., to be made after payment of the final bill and if as a result of such audit and technical examination any sum is found to have been overpaid in respect of any work done by the selected agency under the contract or any work claimed to have been done by him under the contract and found not to have been executed, the selected agency shall be liable to refund the amount of over-payment and it shall be lawful for Government to recover the same from him in the manner prescribed in sub-clause (i) of this clause or in any other manner legally permissible; and if it is found that the selected agency was paid less than what was due to him under the contract in respect of any work executed by him under it, the amount of such under payment shall be duly paid by Government to the selected agency, without any interest thereon whatsoever.

Provided that the Government shall not be entitled to recover any sum overpaid, nor the selected agency shall be entitled to payment of any sum paid short where such payment has been agreed upon between the authorized officer from MoHUA on the one hand and the selected agency on the other under any term of the contract permitting payment for work after assessment by the authorized officer from MoHUA.

29. Lien in respect of claims in other Contracts

Any sum of money due and payable to the selected agency (including the security deposit returnable to him) under the contract may be withheld or retained by way of lien by the Competent Authority or the Government or any other contracting person or persons through Competent Authority against any claim of the Competent Authority or Government or such other person or persons in respect of payment of a sum of money arising out of or under any other contract made by the selected agency with the Competent Authority or the Government or with such other person or persons.

It is an agreed term of the contract that the sum of money so withheld or retained under this clause by the Competent Authority or the Government will be kept withheld or retained as such by the Competent

Authority or the Government or till his claim arising out of the same contract or any other contract is either mutually settled or determined by the arbitration clause or by the competent court, as the case may be and that the selected agency shall have no claim for interest or damages whatsoever on this account or on any other ground in respect of any sum of money withheld or retained under this clause and duly notified as such to the selected agency.

30. Arrangement of water for construction

The selected agency(s) shall make his/their own arrangements for water required for the work and nothing extra will be paid for the same. This will be subject to the following conditions. That the water used by the selected agency(s) shall be fit for construction purposes to the satisfaction of the Competent Authority.

31. Employment of Technical Staff and employees as per Annexure-VIII

Selected agency Superintendence, Supervision, Technical Staff & Employees (i) The selected agency shall provide all necessary superintendence during execution of the work and all along thereafter as may be necessary for proper fulfilling of the obligations under the contract.

The selected agency shall immediately after receiving letter of acceptance of the bid and before commencement of the work, intimate in writing to the Competent Authority, the name(s), qualifications, experience, age, address(s) and other particulars along with certificates, of the principal technical representative to be in charge of the work and other technical representative(s) who will be supervising the work. Minimum requirement of such technical representative(s) and their qualifications and experience shall not be lower than specified in this document. The Competent Authority shall within 3 days of receipt of such communication, intimate in writing his approval or otherwise of such a representative(s) to the selected agency. Any such approval may at any time be withdrawn and in case of such withdrawal, the selected agency shall appoint another such representative(s) according to the provisions of this clause. Decision of the bid accepting authority shall be final and binding on the selected agency in this respect. Such a principal technical representative and other technical representative(s) shall be appointed by the selected agency soon after receipt of the approval from Competent Authority and shall be available at site before start of work.

All the provisions applicable to the principal technical representative under the Clause will also be applicable to other technical representative(s). The principal technical representative and other technical representative(s) shall be present at the site of work for supervision at all times when any construction activity is in progress

and also present himself/themselves, as required, to the Competent Authority and/or his designated representative to take instructions. Instructions given to the principal technical representative or other technical representative(s) shall be deemed to have the same force as if these have been given to the selected agency. The principal technical representative and other technical representative(s) shall be actually available at site fully during all stages of execution of work, during recording/checking/test checking of measurements of works and whenever so required by the Competent Authority and shall also note down instructions conveyed by the Competent Authority or his designated representative(s) in the site order book and shall affix his/their signature in token of noting down the instructions and in token of acceptance of measurements/checked measurements/test checked measurements. The representative(s) shall not look after any other work. Substitutes, duly approved by Competent Authority of the work, in similar manner as aforesaid shall be provided in event of absence of any of the representative(s) by more than two days.

If the Competent Authority, whose decision in this respect is final and binding on the selected agency, is convinced that no such technical representative(s) is/are effectively appointed or is/are effectively attending or fulfilling the provision of this clause, a recovery (nonrefundable) shall be effected from the selected agency as specified in Memorandum in this document and the decision of the Competent Authority as recorded in the site order book and measurement recorded checked/test checked in Measurement Books shall be final and binding on the selected agency. Further if the selected agency fails to appoint suitable technical Principal technical representative and/or other technical representative(s) and if such appointed persons are not effectively present or are absent by more than two days without duly approved substitute or do not discharge their responsibilities satisfactorily, the Competent Authority shall have full powers to suspend the execution of the work until such date as suitable other technical representative(s) is/are appointed and the selected agency shall be held responsible for the delay so caused to the work. The selected agency shall submit a certificate of employment of the technical representative(s) (in the form of copy of Form-16 or CPF deduction issued to the Engineers employed by him) along with every on account bill final bill and shall produce evidence if at any time so required by the Competent Authority.

The selected agency shall provide and employ on the site only such technical assistants as are skilled and experienced in their respective fields and such foremen and supervisory staff as are competent to give proper supervision to the work. The selected agency shall provide and employ skilled, semiskilled and unskilled labour as is necessary for proper and timely execution of the work. The Competent Authority shall

be at liberty to object to and require the selected agency to remove from the works any person who in his opinion misconducts himself, or is incompetent or negligent in the performance of his duties or whose employment is otherwise considered by the Competent Authority to be undesirable. Such person shall not be employed again at works site without the written permission of the Competent Authority and the persons so removed shall be replaced as soon as possible by competent substitutes.

32. Levy/Taxes payable by selected agency

- (i) GST, Building and other Construction Workers Welfare Cess or any other tax, levy or Cess in respect of input for or output by this contract shall be payable by the selected agency and Government shall not entertain any claim whatsoever in this respect except as provided under Clause 38.
- (ii) The selected agency shall deposit royalty and obtain necessary permit for supply of the red bajri, stone, kankar, etc. from local authorities.

If pursuant to or under any law, notification or order any royalty, cess or the like becomes payable by the Government of India and does not any time become payable by the selected agency to the State Government, local authorities in respect of any material used by the selected agency in the works, then in such a case, it shall be lawful to the Government of India and it will have the right and be entitled to recover the amount paid in the circumstances as aforesaid from dues of the selected agency.

33. Conditions for reimbursement of levy/taxes if levied after receipt of bids

- (i) All bided rates shall be inclusive any tax, levy or cess applicable on last stipulated date of receipt of bid including extension if any. No adjustment i.e. increases or decrease shall be made for any variation in the rate of GST, Building and Other Construction Workers Welfare Cess or any tax, levy or cess applicable on inputs. However, effect of variation in rates of GST or Building and Other Construction Workers Welfare Cess or imposition or repeal of any other tax, levy or cess applicable on output of the works contract shall be adjusted on either side, increase or decrease.

Provided further that for Building and Other Construction Workers Welfare Cess or any tax (other than GST), levy or cess varied or imposed after the last date of receipt of bid including extension if any, any increase shall be reimbursed to the selected agency only if the selected agency necessarily and properly pays such increased amount of taxes/levies/cess.

Provided further that such increase including GST shall not be made in the extended period of contract for which the selected agency alone

is responsible for delay as determined by authority for extension of time under Clause 5.

- (ii) The selected agency shall keep necessary books of accounts and other documents for the purpose of this condition as may be necessary and shall allow inspection of the same by a duly authorized representative of the Government and/or the Competent Authority and shall also furnish such other information/document as the Competent Authority may require from time to time.
- (iii) The selected agency shall, within a period of 30 days of the imposition of any such further tax or levy or cess, give a written notice thereof to the Competent Authority that the same is given pursuant to this condition, together with all necessary information relating thereto.

34. Termination of Contract on death of selected agency

Without prejudice to any of the rights or remedies under this contract, if the selected agency dies, the Competent Authority on behalf of the President of India shall have the option of terminating the contract without compensation to the selected agency.

35. If relative working in MoHUA then the selected agency not allowed to bid

The selected agency shall not be permitted to bid for works in the MOHUA responsible for award and execution of contracts in which his near relative is posted as Divisional Accountant or as an officer in any capacity between the grades of the Superintending Engineer and Junior Engineer (both inclusive). He shall also intimate the names of persons who are working with him in any capacity or are subsequently employed by him and who are near relatives to any Gazette Officer in MoHUA. Any breach of this condition by the selected agency would render him liable to be removed from the approved list of selected agency's of this Department. If however, the selected agency is registered in any other department; he shall be debarred from bidding in MoHUA for any breach of this condition.

NOTE: By the term "near relatives" is meant wife, husband, parents and grandparents, children and grand children, brothers and sisters, uncles, aunts and cousins and their corresponding in-laws.

36. Compensation during war like situations

The work (whether fully constructed or not) and all materials, machines, tools and plants, scaffolding, temporary buildings and other things connected therewith shall be at the risk of the selected agency until the work has been delivered to the Competent Authority and a certificate from him to that effect obtained. In the event of the work or any materials properly brought to the site for incorporation in the work

being damaged or destroyed in consequence of hostilities or warlike operation, the selected agency shall when ordered (in writing) by the Competent Authority to remove any debris from the site, collect and properly stack or remove in store all serviceable materials salvaged from the damaged work and shall be paid at the contract rates in accordance with the provision of this agreement for the work of clearing the site of debris, stacking or removal of serviceable material and for reconstruction of all works ordered by the Competent Authority, such payments being in addition to compensation upto the value of the work originally executed before being damaged or destroyed and not paid for. In case of works damaged or destroyed, but not already measured and paid for, the compensation shall be assessed by the Divisional Officer upto Rs.5,000/- and by the Superintending Engineer concerned for a higher amount. The selected agency shall be paid for the damages/destruction suffered and for restoring the material at the rate based on analysis of rates bided for in accordance with the provision of the contract. The certificate of the Competent Authority regarding the quality and quantity of materials and the purpose for which they were collected shall be final and binding on all parties to this contract.

Provided always that no compensation shall be payable for any loss in consequence of hostilities or warlike operations (a) unless the selected agency had taken all such precautions against air raid as are deemed necessary by the A.R.P. Officers or the Competent Authority (b) for any material etc. not on the site of the work or for any tools, plant, machinery, scaffolding, temporary building and other things not intended for the work.

In the event of the selected agency having to carry out reconstruction as aforesaid, he shall be allowed such extension of time for its completion as is considered reasonable by the Authorized Officer.

37. Apprentices Act provisions to be complied with

The selected agency shall comply with the provisions of the Apprentices Act, 1961 and the rules and orders issued there under from time to time. If he fails to do so, his failure will be a breach of the contract and the Authorized Officer may, in his discretion, cancel the contract. The selected agency shall also be liable for any pecuniary liability arising on account of any violation by him of the provisions of the said Act.

38. Release of Security deposit after labour clearance

Release of Security Deposit of the work shall not be refunded till the selected agency produces a clearance certificate from the Labour Officer. As soon as the work is virtually complete, the selected agency shall apply for the clearance certificate to the Labour Officer under intimation to the Competent Authority. The Competent Authority, on

receipt of the said communication, shall write to the Labour Officer to intimate if any complaint is pending against the selected agency in respect of the work. If no complaint is pending, on record till after 3 months after completion of the work and/or no communication is received from the Labour Officer to this effect till six months after the date of completion, it will be deemed to have received the clearance certificate and the Security Deposit will be released if otherwise due.

MEMORANDUM

Sl. No.	Description	Values/Description to be Applicable for Relevant Clause(s) as per Site
1)	Name of Work	Construction of EWS units at LHP site at including all associated facilities and services, development works complete as per scope of work, drawings, etc.
2)	Client/Owner	Ministry of Housing and Urban Affairs, Govt. of India
3)	Type of Bid	EPC
4)	Earnest Money Deposit (for each package)	Rs 2.5 Crore (Rupees Two Crore Fifty Lakh only)
5)	Estimated Cost (of each package)	Rs 125.0 Crore (Rupees One Hundred Twenty Five Crore Only)
6)	Time allowed for Construction of Work (for each package)	12 Months (Twelve Months) from the date of handing over the site and approvals.
7)	Mobilization Advance	Nil
8)	Performance Guarantee	5.00 % (Five Percent Only) of contract value within 15 days from the issue of Letter of Award. Maximum allowable 30 days. After 15 days a late fee @ 0.1% per day of PG amount shall be payable which shall be non-refundable.
9)	Security Deposit / Retention Money	5.00% (Five Percent Only) of the gross value of each running/final bill.
10)	Time allowed for starting the work	The date of start of contract shall be reckoned from the date of handing over the site and approvals.
11)	Escalation	All rates as quoted by participating agency shall be firm and fixed for entire contract period as well as extended period for completion of the works. No escalation shall be applicable on this contract. Escalation cost towards any change in statutory taxes will be accepted.
12)	Defect Liability Period	Five Years after issuance of date of Completion Certificate by MoHUA.
13)	Standard Schedule of rates & specifications	The latest schedule of rates and specification issued by CPWD till the last date of submission of bid shall be followed wherever applicable.

14)	Authority for fixing compensation under Clause-2, Extension of time, Rescheduling of Milestones and Shifting of date of start in case of delay in handing over of site and deciding reduced rates	MoHUA through its authorized representative / agency.		
15)	Description of Milestone			
	S.No.	Description of Milestones D = Date of Award of work D1 = Date of commencement of work on ground (D + 3 months)	Time Allowed in Months	Amount to be withheld in case of non achievement of Milestone
	1	Submission of Inception Report, detailed survey, Architectural drawings ready for submission for approval of local bodies	D+ 1.5 months	0.75%
	2	On approval of local bodies, EIA clearances and other statutory approvals of local bodies, final Architectural drawing showing electrical and sanitary layout plan and drawings and its submission	D + 2 months	
	3	On submission and approval of Vetted structural design by Competent Authority	D + 3 months	
	4	Completion of excavation work, laying of foundation and reaching plinth level of all towers	D1 + 2 months	1.0 %
	5	Completion of Civil works of super-structure of all towers	D1 + 8 months	2.0 %
	6	Completion of residential units fit with all Civil, Electrical, Mechanical services	D1 + 10 months	0.75 %
	7	All Civil, Electrical, Mechanical and Horticulture work completed in all respect in residential and non-residential buildings with services, clearance from local body/ completion certificate require to declare buildings and campus	D1 + 12 months	0.5 %

	authorized for occupation	
	<p>Note:</p> <ol style="list-style-type: none"> 1. In the event of non-achieving the necessary progress as assessed from the running payment, above amount will be withheld for failure of each milestone subject to Maximum 5%. 2. The milestones mentioned at S.No. 1, 2 3 are to be completed within three months from date of award of work, time allowed within S. No. 1, 2, 3. 	
16)	Amount of work done for Running bills	Rs. 12 Crore
17)	Technical representatives required to be engaged at site	As per ANNEXURE-VIII

Performa for JVA

JOINT VENTURE AGREEMENT (ON NON-JUDICIAL STAMP PAPER OF APPROPRIATE VALUE)

JOINT VENTURE AGREEMENT BETWEEN M/S AND M/S FOR SUCCESSFUL PERFORMANCE OF THE CONTRACT FOR(INSERT NAME OF CONTRACT, BRIEF

DESCRIPTION OF WORKS AND NAME OF CLIENT)

This Joint Venture Agreement executed on this day of two thousand and between M/s..... a Company incorporated under the law of And having its Registered Office at (Member-1 having more than 51% of share interest in the JV, Herein after called the “Lead member” Which expression shall include its successors,administrators, executors and permitted assigns) and M/s a Company incorporated under the law of and having its Registered Office at..... (hereinafter called the “Member-2” which expression shall include its successor, administrators Executors and permitted assigns) for the purpose of submitting a bid and entering into a Contract (in case of award) against Bid document No..... invited by MoHUA.....

..... AND

WHEREAS

the Bidding Documents stipulates that the selected agency for participation in the Selection Process may be a single entity or a Joint Venture (JV) of two entities. AND WHERAS the bid is being submitted to the MoHUA on behalf of the JV in accordance with the requirements of the Joint Venture criteria as stipulated in the Bid documents. NOW THEREFORE, THIS DEED WITNESSETH AS UNDER:

1. That All the responsibilities and obligations of each of the Members delineated in this agreement are expressly understood and agreed between the Members. The share of Lead Member shall be% and share of other Member shall be% in the Joint Venture.
2. That in consideration of the Award of Contract by MoHUA to the Member-1 on behalf of JV, we the members to the Joint Venture Agreement do hereby agree that Member-1 shall act as lead member of the JV. The lead member is authorized to deal with the bid, make all correspondence with MoHUA and further to sign the agreement, enter into contract and similar such actions in respect of the bided work.
3. The lead member which shall represent the JV in all the dealings with MoHUA shall be solely and severally responsible for performance of the entire contract for and on behalf of any or both the members of the Joint Venture.
4. JVA shall be valid during the entire currency of the contract including the period of extension, if any. Both the members of the JV shall remain associated with the project till completion of the project. There shall be significant technical contribution of both the members for the project. However, after completion of the project, lead member shall be solely responsible for all responsibilities and liabilities of JV.

5. Once the bid is submitted, the JVA shall not be modified/alterd/terminated during the validity of the bid. In case any member of the JV fails to observe /comply with this stipulation, the full Earnest Money Deposit (EMD) shall be liable to be forfeited. Similarly, after the contract is awarded, the constitution of JV shall not be allowed to be altered during the currency of contract. Failure to observe this stipulation shall be deemed to be the breach of contract with all contractual consequences.

6. No member of the JV shall have the right to assign or transfer the interest right or liability in respect of contract without the written consent of the other member and that of MoHUA.

7. In case of any breach of this Contract committed by any of the Members of the Joint Venture Agreement, both the Members do hereby undertake, declare and

Confirm that both the members shall be solely and severally responsible for Performance of the works in accordance with the terms and conditions of the NIT, for the work of

Bid Document and/or Contract and undertake to carry out all the obligations and responsibilities under this Joint Venture Agreement.

8. If the owner sustains any loss or damage on account of any breach of the contract, the lead member of Joint Venture undertake to pay such loss/damages, caused to the MoHUA on its written demand without any demur, reservation, contest or protest in any manner whatsoever. This is without prejudice to any rights of the MoHUA against the Joint Venture/lead member under the contract and/or guarantees.

9. We agree that this Agreement shall be without any prejudice to the various liabilities of the Joint Venture Members including the performance security as well as other obligations of Joint Venture members in terms of the contract.

10. The Joint Venture members will be fully governed by the terms and conditions of the contract and shall be responsible for the quality of all the works and timely execution thereof to meet the completion schedule under the contract.

11. This Agreement shall be construed and interpreted in accordance with the Laws of India and the respective courts of India shall have exclusive jurisdiction to adjudicate upon the disputes between the parties.

12. We, the Joint Venture members agree that this Agreement shall be irrevocable and shall form an integral part of the Contract. We further agree that this agreement shall continue to be enforceable till the successful completion of contract and till the MoHUA discharges it.

13. On award of contract, a single Performance Bank Guarantee shall be submitted by the lead member on behalf of JV as per bid conditions.

14. This Agreement shall not be construed as establishing or giving effect to any legal entity such as, a company, a partnership, etc. It shall relate solely towards MoHUA/the MoHUA for submission of Bid/Bid and related

execution of works to be performed pursuant to the contract and shall not extend to any other activities.

15. That this Agreement shall be operative from the effective date of the contract.

IN WITNESS WHEREOF, the Joint Venture members through their authorized

Representatives have executed these presents and affixed common seal of their respective companies, on the day, month and year first mentioned above.

For M/s(Joint Venture- Lead Member)

Witness: 1.

For M/s(Joint Venture Member-2)

Witness: 1.

ESTABLISHING SITE LABORATORY AND TESTING OF MATERIALS
(as per Proposed Technology)

Equipments for conducting necessary tests shall be provided and installed at site in the well-furnished site laboratory by the agency at its own cost to establish that the work is being done as per contract specifications and standards. It is also suggested that site laboratory need to be kept at Standard Atmospheric Temperature and humidity.

A SUGGESTIVE LIST OF PLANT AND EQUIPMENT AT SITE

(As per Proposed Technology)- to be provided by the Selected agency

The plant and equipment as required for the technology are to be provided by selected agency here. The space for setting up such onsite facilities shall be provided by State/ ULB/ DA for production of components/ products as applicable.

Minimum Requirement of technical Representative at Site**Requirement of Technical Representative(s) and Recovery Rates**

S. No	Requirement of Technical Staff		Minimum Experience (Years)	Designation of Technical Staff	Rate of recovery if provision of clause 36(i) not fulfilled	
	Qualification	Strength				
1		Graduate Engineer	1 No	20 (and having experience of one similar nature of work)	Project Manager	Rs.1,25,000/- per Month
2	a	Graduate (Civil/Billing) Engineer	1 No	12 (and having experience of one similar nature of work)	Deputy Project Manger	Rs. 80,000/- per Month
	b	Graduate (MEP) Engineer	1 No	-do-	Deputy Project Manger	Rs. 80,000/- per Month
3	a	Civil Graduate Engineer Or Diploma Engineer	2 No.s	5 to 10	Project / site Engineer	Rs. 50,000/- per Month per person
	b	Civil Graduate Engineer Or Diploma Engineer	1 No	5 to 10	Quality Control Engineer	Rs. 50,000/- per Month per person
	c	Electrical Graduate Engineer Or Diploma Engineer	1 No	5 to 10	Project / site Engineer	Rs. 50,000/- per Month per person
	d	Graduate Engineer/ MBA in Project Management	1No	5	Planning Engineer	Rs. 50,000/- per Month per person
4	a	Civil	4 Nos	5	Supervisors	Rs. 30,000/-

	Diploma Engineer					per Month per person
b	Electrical Diploma Engineer	2 Nos	3		Supervisors	Rs. 30,000/- per Month per person
c	Mechanical and Plumbing Engineer	2 No	5		Supervisors	Rs. 30,000/- per Month per person
d	IT/ Communication/ MCA	1 No	5		IT Engineer	Rs. 50,000/- per Month per person

Note:

1. Assistant Engineers retired from Government services, who are holding Diploma will be treated at par with graduate Engineers. Diploma holder with minimum 10-years relevant experience with a reputed construction company can be treated at par with graduate Engineers for such deployment subject to the condition that such Diploma holders should not exceed 50% of requirement of degree engineers.
2. The above given strength shall be required to be deployed as and when necessity arises at site or so directed by Competent Authority.
3. The Selected agency shall submit a certificate of employment of the technical representative(s) along with every account bill/final bill and shall produce evidence of regular physical availability of such engineers on the above project if at any times so required by the Competent Authority.

SECTION-A

General Conditions of Work & Planning and Designing

1. Use of Alternate Technology

- 1.1. The agency shall use “Alternate Technology” which have been presented by them during Construction Technology India – 2019 (CTI-2019): Expo-cum-conference of Global Housing Technology Challenge-India and finally shortlisted by MoHUA for the region. The Technology proposed should have sufficient credentials and authentic performance certification for its soundness by Government Institutes/Organisations.
- 1.2. It will be the responsibility of the agency to establish that the proposed technology is worth adopting for this work and shall provide value addition in respect of quality and time.
- 1.3. The agency shall use the technology listed in Annexure-A for the region and number of storey. The agency shall provide detailed specifications and execution methodology to be adopted for the execution of the work. The agency shall support the proposal along with the details where this technology has been successfully used in the prescribed proforma given in this bid. The agency shall make their own sufficient arrangements for visit to the LHP site at own expense.
- 1.4. It shall be the responsibility of agency to establish the credibility of the technology being proposed by him. The agency shall be responsible for the performance of the technology used and buildings constructed by using this. If agency fails to complete the work with the proposed technology then agency shall be liable to complete the work by using other technology/s as suggested by Competent Authority. The cost incurred in doing so shall be borne by the agency completely.
- 1.5. The MoHUA through BMTPC shall engage an “Independent Agency” for third party quality assurance at their own cost. This independent agency shall be engaged after due approval of Competent Authority. This Independent Agency shall be a Government Institute /Organization/Central PSU.
- 1.6. The agency shall engage professionals with experience of proposed technology as per list mentioned in ANNEXURE-VIII.
- 1.7. All necessary measures like thermal comfort, fire-fighting provisions, natural light and ventilation, etc. shall be taken by the agency to provide as per NBC 2016 and as define in Scope of work earlier in the RFP document.
- 1.8. The necessary suggestions if any, given by the Competent Authority for carrying out the construction work with

alternatetechnology shall be incorporated by the agency for which nothing extra shall be payable.

- 1.9. The agency shall submit the list of laboratories equipments for test and locations of the same along with the proposal of technology. The decision of Competent Authority shall be final in this matter.
- 1.10. The agency shall provide the list and numbers of T&P/ equipments etc. likely to be used for completing the work. The agency shall engage the same during the execution.

2.0 Scope of Work

- 2.1 The work shall be executed in accordance with the site-specific layout plan (same are enclosed in RFP), architectural, structural and services drawings on EPC basis from concept to completion and handing over in fit conditions ready for occupation.
- 2.2 The land is free from encroachment and all encumbrances and there is no hindrance to execute the work. The agency shall fix a permanent bench mark at the site of work. All necessary approvals will be provided by the State/ ULB/ DA on request of selected agency as committed during the LHP proposal by the State Govt. to MoHUA. Plinth level (where stilt is provided) shall be as per CPWD norms however, it should be above existing road level. The general ground level of the whole campus shall be as per CPWD norms above the adjoining external road level. In case of residential units are proposed on ground Level (due to any unavoidable reasons) the plinth level shall be as per CPWD norms above the adjoining external road level. The data provided in this RFP are indicative and for general guidelines. Changes, if any, would not affect the agreed rates and no claim on this account shall be entertained.
- 2.3 Scope of the work shall include but not limited to the following:
 - 2.3.1 To carry out survey of the site handed over for execution of the project and shall verify the site dimensions as per the site plan provided with RFP or made available by Competent Authority.
 - 2.3.2 The agency shall have to prepare the architectural drawings, layout plan for the site accommodating specified numbers of houses and related infrastructure facilities as per prevailing local building bye-laws and development control norms in the area of concerned State. The agency shall prepare all drawings and layouts, get all statutory approvals from concerned authorities.
 - 2.3.3 The agency should attempt sustainable habitat encompassing all environment friendly, energy efficient and barrier free design.
- 2.4 Detailed Soil investigation is to be conducted by the agency as per the relevant BIS code/NBC 2016 for determining type of foundation and its design from the consultant approved by Competent Authority.
- 2.5 Allowable safe bearing capacity for structural design shall be adopted after due approval of MoHUA.
- 2.6 To prepare complete structural design drawings for foundations, superstructure, services, and for other structures to be provided/constructed within works area, as per the provision contained in IS Codes/NBC2016, taking into consideration the protection against seismic/ wind forces required for disaster resistance structures. The structural drawings shall get approved from Competent Authority and to facilitate it, MoHUA may engage consultant for examination of design and advising Competent Authority. After approval of the structural drawings by Competent Authority, if any modification in design/drawing is needed, as per site conditions, the agency shall do/re-do without any extra cost. The decision of the Competent

- Authority shall be final and binding. No claim whatsoever will be entertained on this account.
- 2.7 Planning, designing and execution of all internal services like internal sanitary, water supply, drainage system etc. complete for the buildings planned including all its fittings, fixtures, testing etc.
 - 2.8 Planning, designing and execution of all external services like water supply, rain water harvesting systems, system for recycling of waste water, position of tube wells for horticulture, sewerage, drainage system, roads, paths and all connected sub-structures and superstructures within the premises, as per bye-laws and norms of the local bodies including making connections with the peripheral services after getting the services design approved from the local bodies.
 - 2.9 Planning, designing and construction/installation of underground reservoirs, pump houses for water supply, for firefighting tank including installing of pumps, standby pumps as per approved drawings/specifications or as directed by Competent Authority.
 - 2.10 Planning, designing & installation of waste water recycle system, including all equipments etc. shall be in the scope of the agency. The decision of Competent Authority shall be final.
 - 2.11 Planning, designing and execution of the roof top rain water harvesting system for recharging the sub-soil water including laying of pipe lines and construction of substructure/superstructures. The designs, system shall be adhering to minimum norms define for intensity of rainfall in area and shall got approved from the Competent Authority.
 - 2.12 Preparation of landscaping plan including parks, planters and other details etc. for the horticulture works and execution of same including waste water management system, construction of pump houses and installation of pumps therein etc. complete will be responsibility of selected agency. Development of parks, construction of its boundary wall, providing MS railings (including painting), wicket gates, water hydrants, the grassing, creepers and planting trees etc. shall be completed as per the specification and drawing approved by the Competent Authority.
 - 2.13 Complete leveling/dressing including filling of earth, its supply, disposal of surplus earth is to be completed as directed by the Competent Authority.
 - 2.14 Planning, designing and construction of boundary walls, MS gates, Wicket gates, dustbins, sign boards, guide maps, location boards, direction boards, Numbering of houses etc. all complete as per the drawing approved and direction of Competent Authority.
 - 2.15 Setting up a testing laboratory at site equipped with the apparatus (As per the List of the laboratory equipment given in ANNEXURE-VII of with this bid document) needed for day to day testing of construction materials during construction period as directed by the Competent Authority.
 - 2.16 Taking all precautionary measures to safeguard safety measures against any accidents for the agency's employees, labour, public, and

- staff by providing all necessary safety equipment, helmets etc. at work site.
- 2.17 The agency shall submit a Model of layout plans and unit plans within one month after award of work. The scale of the model shall be adopted suitably so that all the features are clearly distinguished in the model.
- 2.18 The scope as described above is only indicative and not exhaustive. In additions to the above the agency shall be responsible for executing all the items required for completing the houses in all respect to make the dwelling units habitable and ready for occupation with electrical, horticultural works complete as per direction of Competent Authority.
- 2.19 The Environment impact assessment is also a part of the scope of work as such its clearance from Ministry of Environment and Forest Deptt., CPCB & State PCB as applicable is the responsibility of the selected agency. Charges if levied by relevant authority shall be borne by the selected agency.

3.0 General Conditions for Planning & Design

3.1 The selected agency should engage Firms/Consultant (whether titled as an Architectural firm or Engineering firm) which shall provide comprehensive consultancy services in project conceptualization covering space utilization, functional relations, preparation of master plan including obtaining its statutory and local bodies approval, detailed architectural drawings, detailed structural analysis, design and detailing including designing and detailing of all services, their drawings & approval, external development works, landscaping, etc. if in-house consultancy facilities are not available with the selected agency. The cost of consultancy will be borne by the selected agency and separate charges for consultancy shall not be quoted separately. If consultant is hired, consultant shall prepare and supply all the coordinated good for construction drawings duly proof checked and approved. The Consultant shall be associated till completion of the project and obtain completion certificate from the concerned authority.

Such firm / consultant should be an Indian/ foreign consultancy firm and should have in-house Architectural/Engineering capabilities with minimum experience of seven years in the similar field.

3.2 The firms/consultants should have completed following consultancy works during the last seven years ending previous day of last date of submission of bid:

3.2.1 Three consultancy works of similar nature each involving built up plinth area of minimum 16,000sqm.,

or

2.2.2 Two consultancy works of similar nature each involving built up plinth area of minimum 24,000sqm.,

or

2.2.3 One consultancy work of similar nature involving built up plinth area of minimum 32,000sqm.,

3.3 The consultancy works completed up to the previous day of last date of submission of bids shall be considered.

3.4 The firms/consultants should have an average annual Financial Turnover of minimum INR1.0 Cr for consultancy fee during immediate last three consecutive fiscal years. For this purpose, average of annual financial turnover shall be worked out for all the three years.

3.5 In case of non-availability of in-house capabilities in consultancy for any component of Engineering services or Architectural services, the firms/consultants will submit intention to engage/associate sub consultant/firms having domain specific specialization and submit the MOU/Agreement with such specialized firms within fortnight of award of work. The Principle/Main consultant shall engage/associate only those sub consultants/firms for consultancy of domain specific components, which have successfully provided consultancy work at least in two projects costing over all more than INR 100 Cr after the approval of Competent Authority.

- 3.6 The agency shall submit details of financial turnover of firms/consultant in Form 'A' of Technical bid, the details of all consultancy work of consultancy services of similar nature completed by firm/consultant during the last seven years in Form 'C' of Technical bid, performance report of consultancy services in form 'D' of Technical bid, Structure and Organization details in Form 'E' of Technical bid.

3.7 Design Philosophy

- 3.7.1 Should cover at least the followings:

- 3.7.1.1 To cater to the different functional requirements of users including their cultural and occupational preferences, through creatively designed indoor spaces, common areas and circulation. Safe pedestrian spaces between community areas, courtyards, and spaces between buildings in a barrier free built environment to encourage community formation.
- 3.7.1.2 Climate responsive architecture to maximize the use of daylight, ensure thermal comfort, and natural ventilation, shielding, window area disposition, and day lighting to be supplemented with an integrated design of artificial lighting.
- 3.7.1.3 Optimum utilization of renewable energy sources to be duly integrated in the overall energy system design; with consideration of active and passive aspects in building design including thermal performance of building envelope.
- 3.7.1.4 Design shall also incorporate renewable resources for power generation for minimum of 5% of total power consumption, provision for installation of solar street lights, solar lighting for common areas, etc. Excess of power generated through renewable resources will be disposed of to grid as per prevailing State Policy.
- 3.7.1.5 The design basis report shall be submitted by the agency.
- 3.7.1.6 Integrated designs of electrical, mechanical and other services with structural system which should be planned with optimum cost, low maintenance and lowest consumption of energy and water.
- 3.7.1.7 The design and construction shall consider the requirements of Rating 3 of GRIHA Affordable Housing Standards.
- 3.7.1.8 Integrated water and solid waste management with waste water recycling, water conservation and modular rain water harvesting as per CPWD norms.
- 3.7.1.9 Development of site to be sensitive to topographical features and local vegetation.

3.8 Scope of consultancy work

- 3.8.1 Architectural Planning and design:

- 3.8.1.1 Preparation of concept and comprehensive layout plan for the entire area of land conforming to local building bye laws and National Building Code 2016. Architectural

drawings (part of this RFP) are suggestive and for guidance purpose only.

- 3.8.1.2 To carry out site evaluation and prepare 'Site Zoning' and topopose various options for layout of the proposed buildings, their linkages etc. in consultation MoHUA etc.
- 3.8.1.3 Preparation of Building Wise Floor plans in 1: 200 or 1: 100 scale or any other suitable scale as per prior approval of the Competent Authority.
- 3.8.1.4 Preparation of Elevations and Sections wherever required as per prior approval of the Competent Authority.
- 3.8.1.5 Preparation of Typical details in 1: 50 or any other scale as per prior approval of the Competent Authority.
- 3.8.1.6 Preparation of interior design and Room Wise Equipment /furniture layout/furnishing. Equipment layout drawings to be at 1: 100 scale or any other suitable scale as per prior approval of the Competent Authority.
- 3.8.1.7 Any other designing and detailing required for comprehensive planning and designing of the proposed buildings.

3.9 Structural planning and design:

- 3.9.1 Framing and preparation of structural system as per proposed technology.
- 3.9.2 Building/structure wise structural analysis and design using applicable software's.
- 3.9.3 Preparation of building/structure wise preliminary structural drawings.
- 3.9.4 Preparation of building/structure wise detailed structural 'Good for construction's drawings.
- 3.9.5 The structural design shall be carried out in terms of latest editions and up-to-date correction/amendment/errata of BIS Codes (Bureau of Indian Standards), other relevant seismic/other codes for making building hazard resistant for hazard such as earthquake, cyclone, flood, landslide or any other natural calamity, sound engineering practices. The agency will get proof checking of structural drawings with IITs or NITs with prior approval of competent authority for proof checking of structural drawings/proposals prepared by the structural sub consultant/main consultant. The fee for proof checking shall be borne by MoHUA. The consultant will liaison and co-ordinate with such Institute approved by Competent Authority as and when required and as per the direction of Competent Authority.
- 3.9.6 Submission of all design calculations in hard and soft copies as per the direction of Competent Authority.

3.10 Services and Miscellaneous Consultancy works

3.10.1 External Bulk services with schematic planning and design like water supply, sewerage system, storm water drains, boundary wall, gates, underground parking, underground water tanks, rainwater harvesting, STP, roads, paths, horticulture, street furniture, paths, differently able person friendly corridors, signage's, Landscape as per green area norms.

3.10.2 Schematic planning and designing of Internal Electrification, fire-fighting system, Lifts, Electric Sub Station building with all equipments and DG Sets, external lighting, solar power generation and any other essential services/ requirement of the Competent Authority and also required for satisfactory completion of project. The Planning and design should conform to the relevant NBC 2016 and local building bye-laws as applicable.

3.11 Presentations and Models

3.11.1 Preparation of Model(s) to suitable scale decided by Competent Authority.

3.11.2 Preparation of 3D views and blow ups of typical and critical areas and walk through

3.12 Approval from Local Authorities

3.12.1 The agency shall take all necessary statutory approval from all local authorities. Preparation of all submission drawings (any numbers)/materials and models as per the required size/scale as required by local bodies. The State Govt. will facilitate all such fast track statutory approvals.

3.12.2 The agency shall take all necessary statutory approval of 'Completion Plan' from all local bodies as required for occupation of the buildings after completion of construction and preparation of all submission drawings (any numbers)/ materials and models for these approvals.

4.0 Project Management

- 4.1 The Agency shall prepare the phase wise (monthly) resource chart (materials, manpower and machinery) based on the project execution schedule as mentioned in contract conditions.
- 4.2 The Agency shall submit the photographs & videos of progress of work on fortnightly basis to make it possible to create a short film of the entire execution of the work to be kept in archive.
- 4.3 Agency shall submit a detailed monthly progress & program report to the Competent Authority.
- 4.4 The Agency will make it possible to be represented by a senior level executive who have sufficient financial powers to take decisions required for completing the project in time.
- 4.5 The agency shall stick to the construction schedule, if there is any hindrance or delay due to any reason the same shall be mitigated through engaging extra manpower, material and machinery.
- 4.6 The Agency shall submit every month along with “Progress-Report” the details of “Funds-Requirements” for the next three months.

CONTRACT COORDINATION PROCEDURES, COORDINATION MEETINGS AND PROGRESS REPORTING

The agency shall prepare and finalize in consultation with MoHUA, a detailed contract coordination procedure within 15 days from the date of issue of Letter of Award for the purpose of execution of the contract. The agency shall have to attend all the meetings at any place in India at his own cost with MoHUA or consultants of MoHUA during the period of the contract, as and when required and fully cooperate with such personal and agencies involved during these discussions.

- a) A **Project Monitoring Committee (PMC)** will be set up at MoHUA to oversee the entire progress of construction of LHPs at six locations.
- b) The PMC shall work out suitable strategy for routine supervision of the projects as felt necessary.
- c) The PMC shall meet at least once in a month and will report periodic progress of the project to MoHUA till the handing over of the project to State Government. BMTPC as a Technical partner for GHTC-India, shall provide the necessary technical inputs as per requirements.

Being LHPs, these LHPs will also be evaluated and documented by reputed technical institutions. These studies will be undertaken in consultation with MoHUA and cost of such studies will be borne by MoHUA. The agency will facilitate any visits by such Technical Institutes and provide necessary data.

SECTION-B

Conditions & Specifications of Civil and E&M Works

1.0 General Conditions for Civil Works

- 1.1 The work in general shall be carried out in accordance with the CPWD Specifications (corrected up to the last date of submission/uploading of bid) hereinafter referred as CPWD Specifications.
- 1.2 Agency(s) shall provide permanent bench marks, flag tops and other reference points for the proper execution of work and these shall be preserved till the end of the work. All such reference points shall be in relation to the levels and locations, given in the Architectural and plumbing drawings. On completion of work, the Agency(s) shall submit four prints of "as built" drawings to the Competent Authority.
- 1.3 The agency (s) should engage approved, licensed plumbers for the work and get the materials (fixtures/fittings) tested, by the municipal Body/Corporation authorities wherever required at his own cost. The agency(s) shall submit for the approval of the Competent Authority, the name of the plumbing agency proposed to be engaged by him.
- 1.4 The agency shall give performance test of the entire installation(s) as per the specifications in the presence of the Competent Authority or his authorized representative before the work is finally accepted and nothing extra what-so-ever shall be payable to the agency for the test.
- 1.5 The work shall be carried out in accordance with the Architectural drawings and structural drawings approved by the Competent Authority.
- 1.6 Before commencement of any item of work the agency shall correlate all the relevant architectural and structural drawings, and specifications etc. and satisfy himself that the information available is complete and unambiguous. The agency alone shall be responsible for any loss or damage occurring by the commencement of work based on any erroneous and or incomplete information and no claim whatsoever shall be entertained on this account.
- 1.7 The work of services will be executed simultaneously.
- 1.8 If the work is carried out in more than one shift or during night, no claim on this account shall be entertained. The agency must take permission from the police authorities etc. if required for work during night hours, no claim/hindrance on this account shall be considered if work is not allowed during night time.
- 1.9 The agency shall be responsible for the watch and ward/guard of the buildings safety, fittings and fixtures provided by him against pilferage and breakage during the period of installations and thereafter till the building is physically handed over to the department. No extra payment shall be made on this account.
- 1.10 Sample of building materials, fittings and other articles required for execution of work shall be got approved from the Competent Authority before use in the work. The quality of samples brought by the

agency shall be judged by standards laid down in the relevant CPWD/BIS specifications. All materials and articles brought by the agency to the site for use shall conform to the samples approved by the Competent Authority which shall be preserved till the completion of the work.

- 1.11 BIS marked materials except otherwise specified shall be subjected to quality test at the discretion of the Competent Authority besides testing of other materials as per the specifications described for the item/material. Wherever BIS marked materials are brought to the site of work, the agency shall, if required, by the Competent Authority, furnish manufacturer's test certificate or test certificate from approved testing laboratory to establish that the material/procured by the agency for incorporation in the work satisfies the provisions of specifications/BIS codes relevant to the material and/or the work done.
- 1.12 The agency shall procure the required materials in advance so that there is sufficient time to testing of the materials and clearance of the same before use in the work. The agency shall provide at his own cost suitable weighing and measuring arrangements at site for checking the weight/dimensions as may be necessary for execution of work.
- 1.13 Regarding testing of civil & electrical materials, the testing of materials shall be conducted in Govt. Laboratory/Govt. colleges/IITs/NITs or from the laboratory approved by Competent Authority. The charges of testing of materials in approved laboratory shall be borne by the agency.
- 1.14 Agency shall submit minimum "Quality Assurance" plan within 45 days after award of work which shall be consisting of:
 - 1.14.1 Required tests and frequency of components/ products of proposed technology shall be as per national/ international standards as applicable for proposed technology.
 - 1.14.2 Lot-size, number of required tests and frequency of testing. While deciding these criteria CPWD specifications & provisions of BIS Code and standard practices may be referred. Volume of work, practical difficulties and site conditions etc. may also be kept in view. The lot size, number of tests and frequencies of testing can be altered or modified by the Competent Authority from the prescribed limits.
 - 1.14.3 It should clearly indicate the machinery and other Tool & plants required to be deployed at site by the agency. Entire machinery and T&P may not be required at the start of work, therefore, a proper time schedule by which each machinery and T&P is to be brought at site should also be indicated.
 - 1.14.4 Receipt of Material, testing of the same & maintenance of Register of Tests.
 - 1.14.5 All the registers of tests carried out at construction site or in outside laboratories shall be maintained by the agency, which may be inspected by Competent Authority or his/her designee at any point of time.

- 1.14.6 The agency shall allow access to Third Party Quality Assurance Agency (TPQAA) engaged by Competent Authority to have a control on quality and methodology of execution. At least 25% of samples of materials including cement concrete cubes shall be taken jointly by Agency and TPQAA/Competent Authority or his authorized representative. All arrangements for transporting and getting them tested shall be made by the agency.
- 1.14.7 All the test in field lab setup at construction site shall be carried out by the Quality control team to be engaged by the agency which can be witnessed by Competent Authority or his/her designee. A daily report of Tests to be conducted on a day shall be submitted to Competent Authority or his/her designee.
- 1.14.8 All the entries in the registers will be made by the designated Engineering Staff of the agency.
- 1.14.9 Agency shall be responsible for safe custody of all the test registers.
- 1.14.10 Submission of copy of all test registers, material at site register and hindrance register along with each alternate running account bill and final bill shall be mandatory.

1.15 Method Statement

- 1.15.1 The agency shall submit a 'Methods statement' for each important activity for the approval of the Competent Authority soon after the award of work to him. The 'Methods statement' is a statement by which the construction procedures for any activity of construction are formulated and stated in chronological order. The 'Methods statement', should have a description of the item with elaborate procedures in steps to implement the same, the specifications of the materials involved, their testing and acceptance criteria, equipment to be used, Precautions to be taken, steps of measurement, etc.

1.16 Check-list for Execution of work

- 1.16.1 As and when any important item is taken up for execution, the agency shall submit the specifications and develop a checklist and other relevant details. This sample checklist should be got approved from the Competent Authority and should be used at site. This check list should be shown to the Competent Authority or his/her designee during inspection. This procedure is not restricted to the proposed technology and its components but also to be followed for all hidden items, CC/RCC work, Steel-reinforcement, shuttering, cast-in-situ mosaic flooring, doors & windows, plumbing, including water supply pipe lines, roof treatment, earth filling etc.
- 1.16.2 The agency shall be responsible for all documenting the total sequence of this project by way of photography, slides, audio-video recording etc. nothing extra shall be payable to the agency on this account.

1.16.3 General

The agency shall acquaint himself with the proposed site of work, its approach roads, working space available before quoting his rates.

- i. No Entry/exit/roads other than specified by the Competent Authority for purpose of construction activities will be allowed to be used for construction activity purposes or movement of trucks/lorries/load-carriers and nothing extra/delay whatsoever will be accounted for on this part.
- ii. No payment shall be made for any damage caused by rain, snowfall, flood or any other natural calamity, whatsoever during the execution of the work. The agency shall be fully responsible for any damage to the govt. property and work for which the payment has been advanced to him under the contract and he shall make good the same at his risk and cost. The agency shall be fully responsible for safety and security of his material, T&P, machinery brought to the site by him.
- iii. The agency shall ensure that no construction leachate (e.g. cement slurry etc.), is allowed to percolate into the ground. Adequate precautions are to be taken to safeguard against this including, reduction of wasteful curing processes, collection, basic filtering and reuse. The agency shall follow requisite measures for collecting drainage water run-off from construction areas and material storage sites and diverting water flow away from such polluted areas. Temporary drainage channels, perimeter dike/swale, etc. shall be constructed to carry the pollutant-laden water directly to the treatment device or facility (municipal sewer line).
- iv. The agency shall comply with the safety procedures, norms and guidelines (as applicable) as outlined in the document Part 7 Constructional Practices and Safety- 2016, National Building code of India and Bureau of Indian Standards. A copy of all pertinent regulations and notices concerning accidents, injury and first-aid shall be prominently exhibited at the work site. Depending upon the scope & nature of work, a person qualified in first-aid shall be available at work site to render and direct first-aid to casualties. A telephone may be provided to first-aid assistant with telephone numbers of the hospitals displayed. Complete reports of all accidents and action taken thereon shall be forwarded to the competent authorities

1.16.4 The agency shall ensure the following activities for construction workers safety, among other measures:

- i. Guarding all parts of dangerous machinery.
- ii. Precautionary signs for working on machinery.

- iii. Maintaining hoists and lifts, lifting machines, chains, ropes, and other lifting tackles in good condition during the defect liability period.
 - iv. Ensuring that walking surfaces or boards at height are of sound construction and are provided with safety rails or belts.
 - v. Provide protective equipment; helmets etc.
 - vi. Provide measures to prevent fires. Fire extinguishers and buckets of sand to be provided in the fire-prone area and elsewhere.
 - vii. Provide sufficient and suitable light for working during night time.
- 1.16.5 The agency shall provide for adequate number of garbage bins around the construction site and the workers facilities and will be responsible for the proper utilization of these bins for any solid waste generated during the construction. The agency shall ensure that the site and the workers facilities are kept litter free. Separate bins should be provided for plastic, glass, metal, biological and paper waste and labeled in both Hindi and English with suitable symbols.

1.17 Conditions for environment protection

- 1.17.1 The agency shall not store/dump construction material or debris on the metalled road.
- 1.17.2 The agency shall get prior approval from Competent Authority for the area where the construction material or debris can be stored beyond the metalled road. This area shall not cause any obstruction to the free flow of traffic /inconvenience to the pedestrians. It should be ensured by the agency that no accidents occur because such permissible storage.
- 1.17.3 The agency shall ensure that all the trucks or vehicles of any kind which are used for construction purposes/or are carrying construction material like material like cement, sand and other allied material are fully covered. The agency shall take every necessary precaution that the vehicles are properly cleaned and dust free to ensure that enroute their destination, the dust, sand or any other particles are not released in air/contaminate air.
- 1.17.4 The agency shall provide mask to every worker working on the construction site and involved in loading, unloading and carriage of construction material and construction debris to prevent inhalation of dust particles.
- 1.17.5 The agency shall comply all the preventive and protective environmental steps as stated in the MoEF guidelines 2010 and / or any other guidelines issued later on.
- 1.17.6 The agency shall carry out on- road-inspection for black smoke generating machinery. The agency shall use cleaner fuel.

- 1.17.7 The agency shall ensure that all DG set comply emission norms notified by MoEF.
- 1.17.8 The agency shall use vehicles having pollution under control certificate. The emissions can be reduced by a large extent by reducing the speed of a vehicle to 20Kmph. Speed bumps shall be used to ensure speed reduction. In case where speed reduction cannot effectively reduce fugitive dust, the agency shall divert traffic to nearby paved areas.
- 1.17.9 The agency shall ensure that the construction material is covered by tarpaulin. The agency shall take all other precaution to ensure that no dust particles are permitted to pollute air quality because of such storage.
- 1.17.10 The paving of the path for plying of vehicles carrying construction material is more permanent solution to dust control and suitable for longer duration projects.
- 1.17.11 It is mandatory to use of wet jet in grinding and stone cutting.
- 1.17.12 The Agency shall take appropriate protection measures like raising wind breakers of appropriate height on all sides of the plot/area using CGI sheets or plastic and / or other similar material to ensure that no construction material dust fly outside the plot area.
- 1.17.13 Any violation of orders of MoEF including guidelines of State Government, SPCB or any officer of any department shall lead to stoppage of work for which Agency shall be responsible and no hindrance shall be accounted in this regard.

1.18 Miscellaneous

- 1.18.1 A sample flat with proposed technology shall be made ready before starting the execution. The flat should be furnished complete in all respect with doors and windows including fittings, painting, hardware, flooring, painting, electrical services, etc. Nothing extra shall be paid for the sample flat. In case it is not possible to construct sample flat with proposed technology in isolation, the sample flat may be constructed within the tower.
- 1.18.2 Agency shall arrange water for construction from its own sources within the ambit of laws and guidelines issued by the competent authority in this regard. Effort should also be made by selected agency for using recycled water for construction.

2.0 Specifications for Civil Works

2.1 The broad specifications of shortlisted technologies to be used for construction of LHPs are mentioned in **Section F** and need to be followed. As regards procurement and use of cement, steel reinforcement, design mix concrete from batching plant/RMC Plant, etc. and any other required material shall be as per applicable CPWD specifications, relevant Indian Standards and this RFP.

2.4 Waterproofing

- 2.4.1 The work shall be got executed from the specialized agency as approved by the Competent Authority.
- 2.4.2 Agency shall also submit the names of water proofing specialist along with information about their technical capabilities and list of similar works executed by the specialized agency in the past for the approval of Competent Authority within 30 days from the date of award of work who have executed satisfactorily a minimum of three works of value not less than 40% of total work of water proofing to be executed each or two works of value not less than 60% of total work of water proofing to be executed each or one work of value not less than 80% of total work of water proofing to be executed in the last seven years.
- 2.4.3 Total quantity of the water proofing compound required shall be arranged only after obtaining the prior approval of the make by Competent Authority in writing. Materials shall be kept under double lock and key and proper account of the water proofing compound used in the work shall be maintained. It shall be ensured that the consumption of the compound is as per specified requirements.
- 2.4.4 The finished surface after water proofing treatment shall have adequate smooth slope as per the direction of the Competent Authority.
- 2.4.5 Before commencement of treatment on any surface, it shall be ensured that the outlet drain pipes / spouts have been fixed and the spout openings have been eased and rounded off properly for easy flow of water.
- 2.4.6 The approved specialized agency for the work of water proofing will have to execute a guarantee bond in prescribed Proforma enclosed at ANNEXURE-IX for removing any defects for at least 10 years. Guarantee bond shall be signed by both the specialized agencies as approved by the Competent Authority and the agency to meet their liability under the guarantee bond. However, the sole responsibility about the efficiency of water proofing treatment shall rest with the agency.
- 2.4.7 10% of the cost of water proofing work shall be retained as additional security deposit and the amount so withheld would be released after ten years from the date of completion of the entire work under the agreement. If the performance of the work done is found unsatisfactory and any defects noticed during the guarantee period, they shall be rectified by the agency within seven days of receipt of intimation of defects in the work. If the defects pointed out are not attended to within the specified period, the same will be got done from another agency at the risk and cost of the agency.

3.0 General Scope & Specifications of E&M works

3.1 Scope of work

3.1.1 Scope of work covers planning, designing, supply, installation, testing and commissioning of all E&M services such as IEI, Fire Fighting, Fire alarm, D.G. Sets, Lifts, Aviation Light required to be provided in the said scheme as per norms of various IS codes /NBC 2016/CPWD specifications/ECBC/CEA, various byelaws and norms of local bodies. The work shall be executed as per scope & specifications of E & M works given hereafter and given in respective head/part of the scheme sub-head. If any services required to make the building /scheme habitable is not covered in the scope of services same shall either be pointed out in pre-bid meeting else, it shall be presumed that the same shall be provided within the quoted cost and nothing extra shall be paid on this account.

3.1.2 The scope of works also covers the preparation of layout plans, drawings for E&M schemes and approval of the same from the respective local bodies/CFO etc. before the commencement of work. During execution, if the local bodies etc. require a modification, the same shall be executed without any extra cost. Finally, after execution, approvals/NOCs/clearances from local bodies etc. shall be the responsibility of successful agency for which nothing extra is payable in case any modification/ extra work is required. All statutory fees/charges required for obtaining clearances from CEA/Local Bodies shall be paid by the agency.

4.0 General

4.1 These additional terms & conditions are applicable to all the E&M works.

4.1.1 The Agency shall submit within 15 days after award of work an undertaking from the Original Equipment Manufacturers (OEMs) for specialized E&M works regarding:

A) The OEMs shall unconditionally support the lowest agency technically throughout the execution of contract as well as for maintenance/comprehensive maintenance contract for the useful life of the system, and

B) OEMs shall provide all the spares required for healthy functioning of the equipment for at least seven years or useful life of the system whichever is later from the date of supply of equipment. For the above purpose, undertaking may be submitted by OEMs.

4.1.2 The agency must study specifications and conditions carefully. The work shall be executed in close coordination with the progress of building work.

4.1.3 The work shall be carried out as per CPWD specifications, if specifications are not available, IS codes shall be followed.

- 4.1.4 All equipments shall be delivered with (i) manufacturer's test certificate, (ii) manufacturer's technical catalogues, and installation / instruction (O&M) manuals.
- 4.1.5 Scaffolding & any other T&P required for execution of work shall be arranged by the agencies and nothing extra shall be payable on that account.
- 4.1.6 The layout plans/drawings/other documents pertaining to E&M services shall have to be submitted for evaluation & approval, within 45days of award of work.
- 4.1.7 Statutory fees/ payments to Govt. bodies required to be deposited for processing the case, shall be reimbursed by MoHUA on production of actual bills from the concerned department.

5.0 Inspection before Dispatch

All routine tests shall be conducted before dispatch of equipments. No equipment shall be dispatched from the manufacture's premises without such tests being conducted and test result recorded. These test certificates shall be given along with the supply of equipments. The Engineer In-Charge shall, if he so desires inspect and witness the pre-delivery tests. For this purpose, the agency shall give 15 days' notice. Agency shall arrange for inspection by the department. Department shall bear expenses of its officials for inspection as far as traveling, boarding and / lodging is concerned. However, waiver if any, for inspection shall be at the discretion of the department without any cost implication but ROUTINE TEST & TYPE TEST certificates shall have to be submitted for equipments.

Prior to dispatch, all equipments shall be adequately protected & insured for the whole period of transit, storage and erection against corrosion and incidental damages etc. from the effect of vermin, sunlight, rain, heat and humid climate.

6.0 Insurance

The agency shall include storage cum erection insurance including third party insurance right from the storage to commissioning of various equipments. All insurance which the agency is required to enter under the contract shall be affected with any authorized general insurance company and the agency shall produce the policies of insurance.

7.0 Remedy of failure to insure

If the agency fails to effect and keep in force the insurance referred to in the preceding sub-clause the department may affect and keep in force any such insurance and pay such premium as may be necessary for that purpose and from time to time deduct the amount, so paid by the department, from any money due or which may become due to bids or recover the same as debit from the agency's bill.

8.0 Quality of material and workmanship

All parts of the equipment shall be of such design, size and material to function satisfactorily under all rated conditions of operation. All

components of the equipments shall have adequate factor of safety. The work of fabrication and assembly shall conform to sound engineering practice and based on "Fail Safe Design". The mechanical parts subject to wear and tear shall be easily replaceable type. The construction of the equipments shall be such as to facilitate effortless operation, inspection, maintenance and repairs. All connections and contacts shall be designed to minimize risk of accidental short circuits caused by animals, birds and vermin etc. All identical items and their component parts should be completely, interchangeable including spare parts.

9.0 Inspection and testing at site

- 9.1 The installation shall be subject to necessary inspection during every stage of erection, by the Competent Authority. The successful agency shall provide all facilities and assistance for the purpose.
- 9.2 The completed installation shall be inspected and tested by the Competent Authority in the manner as will be laid down by him, in consultation with the agency.
- 9.3 All instruments and facilities necessary for the tests shall be provided by the agency.

10.0 Completeness of work

- 10.1 The installations shall be completed in all respects and put in to operation even where certain details have not been mentioned/left out in these specifications. Any discrepancy may be brought out in pre-bid meeting.
- 10.2 All E&M services such as Internal Electrical installations, lifts, fire fighting system & Addressable fire alarm system shall be declared as completed after completion of trial run of 1 month.

11.0 Internal electric installation (IEI)

- 11.1 The work will be carried out as per proposed technology specifications for the internal electric installation. Where such specifications are not available, CPWD specifications shall be adopted.
- 11.2 FRLS PVC insulated Copper conductor wires will be used for points, circuit & sub-main wiring.
- 11.3 Agency shall execute the work as per scale of amenities given elsewhere in document after obtaining necessary approval of the layout for internal electrification of all houses, common areas and staircases from Competent Authority. The staircase lighting shall be in group control system.
- 11.4 Modular type switches, sockets and stepped type electronic fan regulators, bell push along with matching mounting boxes of same make shall be used.
- 11.5 TV outlet point wiring of each house shall be terminated in suitable size of G.I. box along with splitter at every floor. The interconnections of all splitter boxes fixed at all floors shall be done properly with

conduits to form proper distribution system with the prior approval of competent authority.

- 11.6 Suitable rain protection covers made of 16 SWG galvanized MS sheet wherever required shall be provided.
- 11.7 Meter Boards & Main Distribution Boards as per DISCOM specification/requirement shall also be provided by the agency. Dwelling units shall be provided with single phase 230 V supply.
- 11.8 A separate Meter Rooms for each block of houses is to be provided at suitable location in the housing block with the prior approval of layout by Competent Authority.
- 11.9 Separate shaft for each block of houses shall be provided for laying of Electrical, mechanical & fire services. HDPE/DWC pipes for taking L.T. cables up to meter boards in the meter rooms along with brick masonry chambers of suitable size shall be provided by the agency wherever required.
- 11.10 Laying of HDPE / DWC /Hume pipes for road crossing or in pucca portion & CC path etc. for electric/street lighting cables complete with adequate number of cable chambers shall be provided by the agency.
- 11.11 After completing the work, necessary test results as envisaged in CPWD General Specifications Part-I (Internal)-2005&Indian Electricity Rules 2005, shall be recorded and submitted to MoHUA. The results shall be within the permissible limits. Test report forms duly signed by authorized person for obtaining electric connections (energy meters) from Power Distribution Company by the agency shall be given to the allottees.
- 11.12 Lightning arresters as per IS; 2309 -1989 as amended upto date shall also be provided by successful agency.

12.0 Installation of lift

- 12.1 Provision of lifts in the housing scheme will be kept as per National Building Code-2016/CPWD Specifications considering no of floors, height of the building and speed of elevators which shall be submitted to Competent Authority for approval before commencement of work.
- 12.2 Scope of work of the successful agency shall be inclusive of the following and shall be done by the agency at no extra cost.
 - 12.3.1 Provision of proper ventilation in machine rooms, lift wells and water proof lift pits including lighting.
 - 12.3.2 Electric supply to individual lift shall be given by two independent feeders (one working & other stand by) from main electrical panel through change over switch in the machine room /ground floor panel room.
- 12.3 Agency shall furnish the following drawings and data to the Competent Authority in triplicate, for approval.
 - 12.4.1 General arrangement drawing.

- 12.4.2 Detail of foundations for equipment, load data of various assembled equipments. Data will include breaking load on guides, reactions on buffers, reaction on support in machine room, lift well etc.
 - 12.4.3 Dimensions for every unit and group of units for erection purpose, as required.
 - 12.4.4 The correction/changes, if any, intimated by the Competent Authority shall be incorporated and three sets of such corrected drawing shall be furnished to the Competent Authority within 15 days from the date of approval of drawings. The work shall be executed in accordance with the approved drawings.
- 12.4 Inspection and Testing at Site:
- 12.5.1 The lift installation shall be subject to necessary inspection during every stage of erection, by the Competent Authority or his authorized representative. The bids shall provide all facilities and assistance for the purpose.
 - 12.5.2 On completion of the installation, all adjustments as necessary shall be made for the satisfactory performance of the lifts. The completed installation shall be inspected and tested by the Competent Authority in the manner as will be laid down by him, in consultation with the agency.
- 12.5 Technical Specification
- The lift shall work on microprocessor based control system with self-diagnostic features, site programming to suit the changing need of the user. The lift shall be silent in operation & shall have smooth and controlled acceleration and de-acceleration with leveling accuracy of +5 mm.
- 12.6 Technical Particulars
- 12.7.1 Type of lift.
 - 12.7.2 Rated Speed & Rated load shall be as per approval of Competent Authority.
 - 12.7.3 Type of operation: Automatic group supervisory control with/without attendant.
 - 12.7.4 Type of control: A.C. drive variable voltage variable Frequency with Microprocessor based group control system.
 - 12.7.5 Type car doors: Centre opening stainless steel sliding door in the moon rock finish.
 - 12.7.6 Door Operation: Automatic power operated Construction design & Stainless body with moon rock “honey comb finish” finishing of car body on 3 sides and plain finish on front side shall be given. The car shall be complete with PVC flooring & toe guard of adequate depth cabin fan light fittings with lamps and false

ceiling. Stainless steel hand rails shall also be provided on 3 sides. Disabled friendly lift in each lobby shall be suitable for handicapped persons. (For this purpose, the railing and controlling switch etc. shall be fixed at the appropriate height.

- 12.7.7 Type of signal system: All signal & operating fixtures shall be provided with stainless steel face plates.
- 12.7.8.1 Call registration indication in buttons of operating panel.
- 12.7.8.2 Digital car position indicator in car.
- 12.7.8.3 Digital car position indicator with up & down direction on all floors separately for each lift.
- 12.7.8.4 Luminous hall call buttons on all floors.
- 12.7.8.5 Maintenance free re-chargeable battery operated alarm bell & emergency light.
- 12.7.8.6 Fire man's switch at ground floor for each group of passenger lift.
- 12.7.8.7 Over load warning with visual indication 'OVER LOADED' and audio beep of overloading
- 12.7.8.8 Voice announcement system having standard features.
- 12.7.8 Intercom system in each lift for communication between the passengers in the elevator & fire control room & machine room (press & speak type) with rechargeable maintenance free battery backup.
- 12.7.9 Elevator should be equipped with manual as well as automatic rescue devices.
- 12.7.10 Infra red beam type door safety device shall be provided for full height of door.

13.0 Fire fighting & Fire alarm system

- 13.1 Fire Protection System shall be designed and provided as per NBC 2016 with Amendments, Updated BIS Codes & Fire Bye Laws. NOC for the scheme from Local Fire Service Department shall be obtained by the agency.

14.0 DG set

14.1 DG Sets Installation

- 14.1.1 DG sets outdoor type with radiator cooled, as per CPWD Specifications for Electrical Works. DG Set shall be within an acoustic hood as per CPCB norms. Each DG Set shall be provided with its own day oil tank suitable for at least 10 hrs operations.
- 14.1.2 Standby Power Generation.
- 14.1.3 The capacity of DG set should be worked out with following consideration:
 - i. Total connected Electrical Loads of Common Services viz Staircase light, Lifts, Drinking Water Pumping Sets, External Lighting, Sentry Posts, Mechanical Ventilation.
 - ii. Power Factor – 0.80.

- iii. Provision for Future expansion / addition – 2% of the connected load
- iv. The diversity factor to be, as per the National Electric Code 2011 or latest.
- v. Loading factor.
- vi. DG Sets shall be 400V, 3 Phase, 4 wire, 50Hz, 0.8 PF with acoustic enclosure.

14.2 DG Set Flue Stack

- 14.2.1 As per CPCB norms, flue pipes of DG Sets need to be taken above the roof top of the building, as per CPWD General Specifications for Electrical Works Part VII DG Set – 2013,
- 14.2.2 The flues shall be adequately thermally insulated and properly cladded so as to prevent heat transfer to the supporting walls and adjacent areas.
- 14.2.3 DG exhaust shaft shall be required for the purpose of installing flue pipes for taking them above roof top.
- 14.2.4 DG Set Start/ Stop & change over shall be fully automatic
- 14.2.5 DG sets shall start automatically within 10-30 seconds in the event of a power failure and shall transfer power to emergency/ critical loads automatically.
- 14.2.6 DG Sets operation shall incorporate:
 - i. Auto Start / Stop of DG Sets i.e. auto mains failure.
 - ii. Auto Transfer of Load

14.3 External / Landscape Lighting

- 14.3.1 Security Lights, Road Lighting, open area lighting shall be provided as per codal& functional requirements.
- 14.3.2 Pathways, Garden, Water Bodies & Landscape lighting shall be designed keeping in mind Architectural features/Aesthetic considerations.
- 14.3.3 As a general practice, following type of fixtures/poles shall be used as per CPWD specifications applicable.

Area / Space	Average Illumination Range in Lux	Type of Lamps / Fixtures
Boundary Wall, Road, Parking, Areas	30 – 50 - 100 Lux	LED Lamps Street light fixtures Mounted on 6 to 7m High Octagonal Powder Coated poles.
Pathways, Garden, Water Bodies & Landscape lighting	Aesthetical Consideration	Bollards with LED's / Other Luminaries, as per aesthetical Consideration

15.0 Approved makes

Apart from the proposed technology the following specification/brands names of materials to be used as listed wherever required. The efforts should be made by the agency to use indigenous products. The agency should also consider the availability of spares parts/components for maintenance purposes while proposing any brand/manufacturer. The materials of any other brand/manufacturer may be proposed for use by the agency in case the brands specified below are not available in the market and/or agency intends to use some other brand better than the brands mentioned in this list. The alternate brand can be used only after the approval of Competent Authority. The list of approved make for Civil Works is given below:

Sl. No	Materials	Approved make
For Civil Works		
1.	PPC / OPC CEMENT	ACC / ULTRATECH / AMBUJA / JK BIRLA
2.	WHITE CEMENT	J.K. WHITE / BIRLA WHITE / TRAVANCORE
3.	REINFORCEMENT STEEL	TATA / SAIL / JINDAL STEEL / RINL
4.	STRUCTURAL STEEL SECTIONS	SAIL / TATA STEEL Ltd. /RINL AND JINDAL STEEL & POWER Ltd
5.	AAC BLOCK	BUILTECH / MAGICRETE BUILDING SOLUTION / AEROCON/INDO BHUTAN CONSTRUCTION SOLUTION
6.	AAC BLOCK ADHESIVE	ULTRATECH / FERROUSCRETE / BAL ENDURA
7.	POLYMER MODIFIED CEMENTITIOUS GROUT	BAL ENDURA / WEBBER / MYK LATICRETE
8.	EPOXY MORTAR	FOSROC / SIKA / CICO / LATICRETE
9.	FLUSH DOORS	GREEN / DURO / MERINO / MAYUR / ARCHID / KUTTY
10.	UPVC WINDOWS/ DOORS / VENTILATORS	ENCRAFT / ALUPLAST / REHAU / DUROPLAST
11.	WOODEN / METAL / GLAZE- FIRE RATED DOOR SHUTTERS	NAVAIR / SUKRI / PROMAT / KUTTY /BHAWANI / PACIFIC
12.	HINGES & BRASSWARE	SHALIMAR/ INDO-BRASS / AMARBHOY DOSSAJI / EARL BIHARI / MAGNUM/KICH

13.	ALL TYPES OF GLASS	AIS / MODIGUARD / PILKINGTON / GLAVERBEL / SAINT GOBBIN
14.	FIRE-RATED GLASS (TWO HOUR FIRE RATING) TRANSPARENT CLEAR GLASS	GLAVERBEL / SAINT GOBBIN / PYROGUARD / SHOTT
15.	ALL HARDWARE AND FITTINGS FOR ALL TYPES OF GLAZING / DOORS / WINDOWS ETC.	DORMA / HAFELE / GEZEI / KICH / GODREJ / ASSA-ABLOY
16.	ADHESIVES	ANCHOR / DUNLOP / PIDILITE-FEVICOL
17.	STAINLESS STEEL DOOR HANDELS / LOCKS AND FITTINGS	DORMA / HAFELE / GEZE / GODREJ / KICH / IPSA / ASSA-ABLOY
18.	SS MESH	GKD / WMW
19.	COMMERCIAL PLY / BOARD	DURO / CENTURY / ARCHID / DURIAN
20.	HARDWARE ACCESSORIES FOR FIRE DOORS / PANIC BAR / PANIC TRIM / DOOR CLOSER / HINGES / MORTISE LOCK	INDERSOLL ROND / DORMA/ GEZE / HAFELE / ASSA-ABLOY / KICH
21.	VITREOUS CHINA WARE	HINDWARE / PARRYWARE / CERA / JOHNSON / KEROVIT
22.	RCC PIPES	PRAGATI / LAKSHMI / SOOD & SOOD / JAIN & CO
23.	UPVC / CPVC PIPES & FITTINGS	SUPREME / PRINCE / ASTRAL / FINOLEX / SURYA ROSHNI / ASHIRWAD
24.	STAINLESS STEEL SINKS	NEELKANTH / NIRALI / CERA
25.	SPUN CAST IRON PIPES & FITTINGS (IS:3989)	JAIWAL NECO/ RIF / SKF / BIC
26.	STONEWARE PIPES AND GULLY TRAPS	PERFECT / BURN / ANAND / PARRY
27.	GUNMETAL VALVES (FULL WAY VALVE) CLASS-I	ZOLOTO / CASTLE/ KARTAR
28.	CI DOUBLE FLANGED SLUICE VALVE	KIRLOSKAR / IVC / SONDHI / KEJRIWAL

29.	CI MANHOLE FRAME & COVERS AND CI GRATING	NECO / RIF / SKF / BIC
30.	SANITARY CP FITTINGS & ACCESSORIES	ORIENTAL SERIES OF MARC OR EQUIVALENT SERIES OF JAQUAR / PARRYWARE / GROHE / KOHLER
31.	FLOOR TRAPS	JAYNA / CHILLY / NIRALI
32.	PVC WATER TANK	SINTEX / POLYCON / SPL.
33.	CERAMIC TILES / VITRIFIED TILES	H & R JOHNSON / SOMANY / KAJARIA / ASIAN (AGL)
34.	SYTHETIC ENAMEL PAINT / PRIMER / DISTEMPER / EXTERIOR DECORATIVE PAINT	1st QUALITY PRODUCTS OF: ASIAN / BERGER / ICI (DULUX) / NEROLAC
35.	WALL PUTTY / COURSE PUTTY	1st QUALITY PRODUCTS OF: BIRLA WHITE / J.K WHITE / FERROUS CRETE / BERGER
36.	TILE ADHESIVE / EPOXY GROUTS	FERROUS CRETE / BALL ENDURA / PIDILITE / LATI CRETE
37.	PAVERS / GRASS PAVERS / KERB STONE	UNISTONE / ULTRA / HINDUSTAN / K.K.
38.	BUILDING SIGNAGE	HINDUSTAN SIGNAGE PVT.LTD / PR GRAPHICS / MOTIVATTE SOLUTION / GALAXY SIGNAGE, SIGNSUTRA
39	Structural Steel	SAIL,RINL,TATA STEEL, JINDAL, ESSAR OR AS APPROVED BY CLIENT(BMM ISPAT LTD)
40	Electrodes	ADOR (ADVANIORLIKON), D & H, ESAE OR EQUIVALENT APPROVED MANUFACTURES AS APPROVED BY CLIENT(BMMISPATLTD).
41	Paint	BERGER, SHALIMAR, AKZO-NOBEL,SIGMA COATING, ASIAN PAINTS, GRAND POLYCOAT OR AS APPROVED BY BMM ISPATLTD.

	For Electrical Works	
1.	FRLS PVC insulated copper wire /Power cable / XLPE Cable / Telephone cable	L&T / HAVEL'S / POLYCAB / FINOLEX / SKY TONE.
2.	Co-axial TV cable	L&T / HAVEL'S / POLYCAB / FINOLEX / SKY TONE.
3.	Steel Conduit	RM CON / AKG / BEC ISI MARKED.
4.	PVC Conduit	AKG / POLYCAB / PRINCE ISI MARKED.
5.	L. T. Panel / <u>Meter Board</u>	ADLECMUNDKA / ASSOCIATED SWITCHGEARS AND PROJECT LTD. / SUDHIR GENSET LTD. / CONTROL AND SWITCHGEARS PVT. LTD / KEPL /TRICOLITE
6.	MCB/MCB DB, prewired MCB DB and sheet steel Metal enclosed industrial socket, plug top and Isolators	LEGRAND / SIEMENS / L&T / ABB / SCHNEIDER
7.	Modular type switch/Socket, Telephone socket, cable TV Antenna socket, Electronic fan regulator and GI Boxes	LEGRAND (MYLINC / HAVEL'S (PICCADILLY) / HONEYWELL (MIDAS) /NORTH WEST (NOVA)
8.	LED fitting	PHILIPS / CROMPTON / WIPRO / GE / ZUMPOBEL / TRILUX
9.	Ceiling Fan / Exhaust fan	CROMPTON GREAVES / ALMONARD / HAVELLS / USHA.
10.	Octagonal steel pole	BAJAJ/ TWINKLE / VALMART
11.	Air Circuit Breaker / MCCB.	L&T-U POWER / SIEMENS-3WL / ABB-EMAX / SCHNEIDER-MASTERPACT-NW
12.	Fire Extinguishers	SAFEX/ MINIMEX / SUPEREX / CEASFIRE
13.	Diesel operated Power Generating Engine	CUMMINS INDIA / CATERPILLAR / PERKINS / KOEL GREEN
14.	Alternator	STAMFORD / LEROY SOMER / CATERPILLAR / KOEL GREEN
15.	LIFTS	1. M/S OTIS 2. M/S KONE 3. M/S MITSUBISHI

		4. M/S SCHINDLER 5. M/S JOHNSON LIFTS PVT. LTD. CHENNAI
16.	Copper Conductor Control Cable	BONTON / LAPP CABLE / HAVELLS / RR KABEL / L&T / RAJNIGANDHA
17.	Communication Cable / Signal Cable	LAPP CABLE / FUSION POLYMER / BELDON
18.	Fire / Sprinkler Main Pump / Jockey Pump	MATHER & PLATT INDIA LIMITED / GRUNDFOS / KIRLOSKAR / KSB
19.	Diesel Engine	CUMMINS / KIRLOSKAR / CATEPILLAR
20.	Motor	ABB/ SIEMENS/ KIRLOSKAR / CROMPTON GREAVES
21.	Anti Vibration Mounting	KANWAL INDUSTRIAL CORPORATION / RESISTOFLEX / EWREN
22.	Starter	L&T/ SIEMENS / CROMPTON/ GE / ABB / BCH
23.	Addressable Multicriteria Smoke Detectors With base / Addressable Duct Type Smoke Detectors With base/ Fault Isolator with base/ Addressable Heat Detectors with base/ Addressable Manual Call points / Addressable Control Module / Addressable Monitor Module / Sounder/ Hooter cum Strobe/ Fire Alarm Control Panel/ PA System Panel/ Telephone Jack / Hand Set/ Software/ Speaker	NOTIFIER / SIEMENS / BOSCH / EDWARD.
24.	Fireman Axe/ Installation Control Valve	SAFEX/ PADMINI / GETECH
25.	2-way/4-way FBC	SAFEX/ NEWAGE (MUMBAI) / GETECH
26.	Window Sprinkler	TYCO / HD
27.	Deluge Valve	SAFEX/ TYCO / HD
28.	Air release valve	SUPEREX/ GETECH / NEWAGE / SAFEX

GUARANTEE TO BE EXECUTED BY AGENCY FOR REMOVAL OF DEFECTS AFTER COMPLETION IN RESPECT OF WATER PROOFING WORKS

The agreement made this.....day of year two thousand andbetween
(Hereinafter called the Guarantor of the one part) and the PRESIDENT OF INDIA (Hereinafter called the Government of the other part).

WHEREAS THIS agreement is supplementary to a contract (Hereinafter called the contract) dated and made between the GUARANTOR OF THE ONE PART AND the Government of the other part, whereby the agency inter-alia, undertook to render the building and structures in the said contract recited completely water and leak proof.

AND WHEREAS THE GUARANTOR agreed to give guarantee to the effect that the said work will remain water and leak proof for ten years from the date of giving of water proofing treatment.

NOW THE GUARANTOR hereby guarantee that water proofing treatment given by him will render the structures completely leak proof and the minimum life of such water proofing treatment shall be ten years to be reckoned from the date after the maintenance period prescribed in the contract.

Provided that the guarantor will not be responsible for leakage caused by earthquake or structural defects or misuse or alteration and for such purpose.

- a) Misuse of roof shall mean any operation which will damage proofing treatment, like chopping of firewood and things of the same nature which might cause damage to the proof.
- b) Alteration shall mean construction of an additional storey or a part of the roof or construction adjoining to existing roof whereby proofing treatment is removed in parts.
- c) The decision of the Competent Authority with regard to nature and cause of defects shall be final.

During this period of guarantee, the guarantor shall make good all defects and in case of any defect being found render the building water proof to the satisfaction of the Competent Authority at his cost and shall commence the work for such rectification within seven days from the date of issue of the notice from Competent Authority calling upon him to rectify the defects failing which the work shall be got done by the Department by some other agency at the Guarantors risk and cost. The decision of the Competent Authority as to the cost payable by the Guarantor shall be final and binding.

That if guarantor fails to execute the water proofing or commits breach there under; then the guarantor will indemnify the Principal and his successors against all loss, damage, cost any default on the part of the GUARANTOR in performance and observance of this supplementary agreement. As to the amount of loss and/ or damage and/or cost incurred by the Government, the decision of the Competent Authority will be final and binding on the parties.

IN WITNESS WHEREOF these presents have been executed by the obligator andBy..... For and on behalf of the PRESIDENT OF INDIA on the day, month and year first above written.

SIGNED, sealed and delivered by OBLIGATOR in the presence of :

1. 2.

SIGNED FOR AND ON BEHALF OF MoHUA

By in the presence of :

1. 2.

SECTION-C

Architectural Design Norms, Schedule of Finishes & General

Specifications

1.0 Norms Applicable & Scale of Amenities for Residential Units

1.1 Plinth Area

The following norms (variation +2%) shall be adopted for Residential Units:

S. No	Type	Unit Carpet Area	Staircase/ Circulation	Balcony	Utility area/Balcony
		(Main) Sqm	Sqm	Sqm	Sqm
1.	EWS	As per designs following NBC 2016 norms and guidelines of PMAY(U)			

2.0 Scale of Amenities

The following composition shall be adopted for residential units as per provisions of Requirements of low Income housing in NBC :2016 and guidelines of PMAY (Urban)

Overall planning at site should be done to maximize the density of housing with well organized green spaces and adequate width of

S. No	House Category	Living Room	Bed Room-one	Kitchen	Balcony	Toilets
1.	EWS	one	One	One	One	One (separate bath and WC)

roads for proper movements.

2.1 Scale of Amenities (Minimum) :

Items No	Item	To be provided
1	Kitchen Cabinets	-
	i) Cooking Platform with hole for cylinder pipe	Yes
	ii) Stainless Steel AISI 304 (18/8) Kitchen sink as per IS 13983 with drain board	Yes
	iii) Built in cupboard below cooking platform as per architectural design.	yes
2	Wardrobes	

	i)	Built in cupboard	In bed room up to ceiling height
3		Magic Eye (of SS grade 316) in front entry door	One
5		Set of Pegs SS grade 304	In toilet
6		18mm thick projected window Sill	Kota (If permitted as per the technology proposed)
7		WC with seats in toilets	
	i)	European-type floor mounted/wall-hung WC with seat, lid and low level flushing PVC cistern, water jet/health faucet. or Orissa pan WC with seat, lid and low level flushing PVC cistern.	In toilet, as approved
8		Wash Basin with CP Brass type Pillar Cock provided with quarter turns	One as per design, either outside of bath/toilet or inside bath
9		Tap (Kitchen, toilet,bath) CP Brass bib cock provided with quarter turns.	1 in Kitchen 1 in toilet 1 in Bath
10		Provision for shower	1 in Bath
11		Tower rail of SS grade 304	One in Bath
		Soap rack/Niche as per architectural Design and Specifications	1 in toilet
14		Plumbing for water purifier and Geyser.	Yes

2.2 Scale of Electrical Amenities (Minimum)

S. No	Description	Type / category of Accommodation
1	Power Points (15 amp 6 pins)	1 in each Room 1 in Kitchen 1 in Utility Area 1 in Bath Total 5
2	Plug Points	1 in each Room

	(5 amp)	1 in Kitchen 1 in Balcony 1 in Bath 1 in utility area 1 near washbasin Total 7
3	Provisions for Bracket Lights (with normal fittings excluding lamp/bulb)	1 in each Room 1 in Kitchen 1 in Toilet and Bath 1 in washbasin 1 in Balcony Total 7
4	Provision for Ceiling Fans	1 in each room Total 2
5	Call Bell Points	1 on Main Door
6	Provision for Exhaust Fans	1 in each Kitchen & Toilet
7	AC Points (with MCB connected socket outlet with wiring)	1 in each Room
8	Geyser Point (with MCB connected socket outlet with wiring)	1 in bath and kitchen (Geysers are not to be provided)
9	EDB/MCB Point (single phase)	1 at appropriate place
10	Cable TV Point	1 in each room
12	LED tube light fitting (excluding tube)	1 in each Room 1 in Kitchen Total 3
13	Modular Switches	Yes
14	Common areas of basement/stilt/residential towers	As per requirement of light intensity, fittings with lights (consumables) shall be fixed.

2.3 General Specifications

2.3.1 For Residential Units:

S.No.	DESCRIPTION	Residential houses
1.	Finishes	
	External Walls	It should be as per the requirement of proposed technology. However, External surface shall be made smooth with coarse putty before painting work
	Internal Walls & Ceiling	It should be as per the requirement of proposed technology. However, surface shall be made smooth with putty before painting work if required.
	Living Room	Low VOC Acrylic washable distemper
	All Bedrooms	Low VOC Acrylic washable distemper
	Kitchen	Low VOC Acrylic washable distemper
		Ceramic Tiles on all walls up to 6 feet height
	Toilets/ Bath	Ceramic tiles on all walls upto 6 feet height.
	External Finishes	As per the architectural design
Ceiling	Low VOC Acrylic washable distemper	
2.	Flooring	
	Living room	Vitrified anti skid tiles (600mmx600mm) laid as per CPWD specifications.
	Bedroom	Vitrified anti skid tiles (600mmx600mm) laid as per CPWD specifications.
	kitchen	Vitrified tiles of (600mm x 600mm) laid as per CPWD specifications.
	Toilets/ Bath	Anti-skid ceramic tiles laid as per CPWD specifications.
	Balcony	Anti-skid ceramic tiles 300mm x 300mm laid as per CPWD specification.
	Common Circulation	Pre-Polished Kota Stone in single length of treads & riser

	Area	
	Staircase	Pre-Polished Kota Stone in single length of treads & riser
	Skirting / Dado / Wall Cladding	Skirting / Dado / Wall Cladding shall be matching with the floor with adhesive, as given below (i)100 mm high skirting matching the floor material (ii)Minimum 900 mm Dado in corridors / walkways
	Kitchen Platform	Pre-polished Granite Stone with nosing
3.	Door & Window Frames, Shutters and Hardware Fittings	
	Main Entrance Door Frame & Shutter	Frame of external door shall be made with pressed steel/ MS Angle iron (i)Outer Shutter shall be of MS with mosquito proof wire mesh with grill (ii)Inner shutter shall be 35mm thick factory made enamel painted.
	Door Frames	pressed steel/ MS Angle iron
	Window Frame	All frames of external windows must have double rebates for fixing same material frame with mosquito proof wire mesh
		UPVC extruded frame sections with wall thickness min. 2.0mm
	Door shutters	The door shutter shall be ISI marked flush door shutters conforming to IS 2202 (Part 1) Non decorative type,core of block board construction with frame of 1st class hard wood and well matched commercial 3 ply veneering with vertical grains or cross bands and face veneers on both faces of shutters .35 mm thick including ISI marked stainless Steel butt hinges with necessary screws with 25mm lipping
	Door Fittings	ISI marked Aluminium fittings e.g. Tower bolts, handles, door stopper etc. (IS:1378) Handles 150 mm -2, Tower bolt 12mm dia 300mm length -2, L drop- 300mm long & 16mm dia-1, Stopper-1, Buffer -1
	Toilets shutters	- 24 mm thick factory made PVC door shutters made of styles and rails of an uPVC hollow section of size

		59x24 mm and wall thickness 2 mm (\pm 0.2 mm) with inbuilt edging on both sides. The styles and rails mitered and joint at the corners by means of M.S. galvanized /plastic brackets of size 75x220 mm having wall thickness 1.0 mm and stainless steel screws. The styles of the shutter reinforced by inserting galvanized M.S. tube of size 20x20 mm and 1 mm (\pm 0.1 mm) wall thickness. The lock rail made up of 'H' section, an uPVC hollow section of size 100x24 mm and 2 mm (\pm 0.2 mm) wall thickness, fixed to the shutter styles by means of plastic/galvanized M.S. 'U' cleats. The shutter frame filled with an uPVC multi-chambered single panel of size not less than 620 mm, having over all thickness of 20 mm and 1 mm (\pm 0.1 mm) wall thickness. The panels filled vertically and tie bar at two places by inserting horizontally 6 mm galvanized M.S. rod and fastened with nuts and washers, complete as per manufacturer's specification and direction of Competent Authority. (For W.C. and bathroom door shutter)
	Kitchen doors	35mm thick shutter having 12mm thick pre-laminated particle board panel at the bottom part and MS wire mesh at upper part
	Window Shutter	Three track UPVC frame with double shutter one with glazed panel & other with wire mesh (of SS grade 304) shutter
	Fittings for Doors	Sliding door bolts, two tower bolts (250x10mm) and handles (125mm) of SS grade 304
	Fittings for Windows	Two tower bolts (150x10mm) and handles (100mm) of SS grade 304
4.	Water supply lines	
	External Pipeline up to 50mm	CPVC
	Internal Piping-Exposed on wall	CPVC
	Internal Piping – Concealed work	CPVC
	Soil & Waste Pipes and Fittings	UPVC
	Rainwater pipe and Fittings	Un-plasticised PVC rainwater pipe and un-plasticised PVC moulded fittings & accessories
5.	Water Proofing	

	Terrace of Top floor	As per technology proposed otherwise Koba treatment as per CPWD specification
	Sunken Area	As per technology proposed otherwise cement slurry
6.	Railing	
	Railing (balcony)	0.90mtr high M.S. railing in all the units in staircase of approved pattern with hand railing 40 mm MS (medium class pipe) Minimum weight 14 kg per meter and vertical bars of 12mm dia square bar at 100mm c/c embedded in waist slab.(as per Drawing) The height of railing shall be 0.90mtr from finished level of steps. (Drg. to be approved by Competent Authority).
	Railing (staircase)	same as above
7.	Miscellaneous	
	Plinth Protection:	50mm CC M -15 grade over 75mm bed of CC M -10 grade
	Numbering of houses:	The granite plate of 300 x 375 mm at height of 1200 mm from floor level at side of entrance door mentioning GHTC-India logo, beneficiary name, flat no., etc.
	Numbering at other places	The numbering of size 75mm in height shall be written with ISI marked enamel paint on overhead tanks,water meter box etc complete as per direction of Competent Authority

2.4 SPECIFICATIONS OF DEVELOPMENT WORKS: Specifications To Be Adopted for On-Site Infrastructure Work

ROADS

- a. Internal Roads: The internal roads feeding the houses will be of 100 mm thick RCC of not less than M25 grade over a base course of PCC not less than M7.5 grade (100mm thick).
- b. Peripheral Roads and pathways (as shown in drawing). “Providing and laying factory made chamfered edge Rubber Molded concrete colored paver blocks of required strength, thickness & size/shape, made by table vibratory method, to attain superior smooth finish using PU or equivalent moulds, laid in required mix of colour & pattern over 50mm thick compacted bed of coarse sand, compacting and proper embedding / laying of inter locking paver blocks into the sand bedding layer through vibratory compaction by using plate vibrator, filling the joints with fine sand and cutting of paver blocks as per required size and pattern, finishing and sweeping extra sand in footpath, parks, lawns, drive ways or light traffic parking etc. all complete as per manufacturer’s specifications & direction of Competent Authority: 80 mm thick c.c. paver block of M-30 grade with approved color design”.

The peripheral road, pathways and internal roads should be as per the CPWD specifications.

WATER SUPPLY

50 mm dia 6 kgf/cm² UPVC including all required fitting etc. as required including connection with existing line.

SEWERAGE SYSTEM

150mm dia. PVC pipe as per IS:14333 and IS:10910 of sq.cm with required Manholes etc. to be provided.

RAIN WATER HARVESTING TANK

Modular Rain Water Harvesting tank of required size will be constructed as per the CPWD specifications.

EXTERNAL ELECTRIFICATION WORK

Electric Panel: As necessary for the layout feeder Pillar Floor mounting totally enclosed compartmentalized cubical, dust vermin proof and outdoor type with required Earthing plate and bus bar complete including connections etc.

- Providing and Laying require Electrical cable for providing electrical supply to units, as approved.
- Providing and fixing street solar Lights as required including fixture and ESL, as per CPWD specifications.
- Making required connections to Building and flats.

- Providing and fixing solar light connection in stair case and common area.
- P/Laying XLPE insulated / P.V.C. sheathed cable of 1.1 KV grade with aluminum conductor Armored of IS:7098-I/1554-1 approved make in ground as per IS:1255 including excavation of 30cmx75cm size trench, 25 cm thick under layer of sand, 2nd class bricks covering, refilling earth, compaction of earth, making necessary connection, testing etc. as required of size.
 - a. 35.0 Sq.mm 3.5 core
 - b. 6.0 Sq.mm 2 core
 - c. 4.0 Sq.mm 2 Core

BOUNDARY WALL with gates

The selected agency may like to use his proposed alternate technology for construction of boundary walls. Its height shall be minimum 2.1 mtr. high and 0.6 mtr. fencing with proper water proofing and drainage.

Or,

Brick / Block Masonry with R.C.C intermittent columns having grill of approved pattern and coping of CC 1:2:4 (1 cement: 2 Coarse sand: 4 graded stone aggregate) on top of wall with pointing as per approved drawing. Height of boundary wall shall be minimum 2.1 mtr. height solid wall and 0.6 mtr fencing above solid wall to make area secured.

EXTERNAL DEVELOPMENT WORKS

A. SPECIFICATIONS FOR WATER SUPPLY :

1. **Scope:** It includes excavation for pipes, laying of Ductile Iron pipes K-9 with necessary fittings, sluice valves, fire hydrants, air valves with necessary brick chambers, jointing of pipes and fittings, accessories, refilling of trenches and testing for leakage disinfection etc. complete to the satisfaction of Competent Authority as per approved scheme in the specified boundary / area.
2. The water line system shall be laid as per the scheme approved by local authority. The sluice valves, fire-hydrants and air valves shall be IS marked. Any modification in this scheme approved by the Competent Authority shall not violate terms of contract. The work shall be executed as per latest CPWD Specification with upto date correction slips and the relevant IS Codes shall be followed.
3. **Excavation:** The work includes excavation in all types of strata. For proper jointing of pipes and fittings the bottom of the trench and sides at the relevant places should be sufficient for doing proper lead caulking of joints. The top of the pipes would have at least cushion of 60 cm from the finished surface under road berms and 1.2 M under roads or as per direction of Competent Authority.

4. Ductile Iron pipes K-9 pipes duly approved by the Competent Authority shall be used in the work. All collar jointed/flanged/ socketed fittings shall be of heavy class.
5. **Laying:** The Ductile Iron pipes K-9 shall be laid as per alignment shown in the approved drawings. In case it is considered necessary by the Competent Authority to alter the alignment as per site situations, so as to accommodate laying of other services viz. storm water drain, sewerage, horticulture pipes, and electric cables, no extra claims for the same would be entertained. While laying the pipes, it may be ensured that these water supply pipes have a horizontal and vertical separation of 3 meters and 0.5 meter respectively from the sewer pipes. The water line should in no case run below sewer line.
6. **Jointing:** Water supply pipes, fittings and specials shall be jointed together with pig lead or flanged joints where necessary as per direction of Competent Authority. The pig lead brought at site shall be got tested from laboratory and only after the results are found to be satisfactory the same would be allowed to be used in the work and shall remain in joint custody. The day to day consumption of lead shall be maintained by the Junior Competent Authority and the same would be signed by the agency as well. The quantity of lead to be used in joints of pipes, fittings and specials would be as per CPWD Specifications / IS Codes.
7. **Chambers:** Suitable fly ash brick chambers for housing the fire hydrants and sluice valves shall be constructed in brick masonry with bricks of class designation 75 in CM 1:5. The brick chambers shall have leveling course of CC 1:5:10, the chamber shall be plastered with CM 1:3, 12mm thick with a floating coat of neat cement. The chambers shall have RCC slab on top with required opening for operation of valves as per MS Specifications, indicating plate showing the positions of fire hydrants, and sluice valves also be provided.
8. Cement Concrete 1:2:4, thrusts blocks shall be provided as per CPWD Specifications for the various fittings/accessories.
9. **Disinfection/Testing:** After the work has been completed the lines shall be flushed with water containing bleaching powder @0.5gms/litre of water and cleaned with fresh water and the operation repeated 3 times till the sample of water is approved by Municipal Laboratory.

Pipes laid shall be tested at twice the maximum allowable pressure to check water tightness of the joints and to detect any hair cracks in the pipes. After satisfactory completion of the work, 5 sets of completion plans, showing the alignment of lines, location of air valves, sluice valves, fire hydrants along with.
10. The work may be inspected by officials of local municipal/statutory authority or any other agency designated by MoHUA during execution.

11. UGR of required capacity with boosting arrangement in pump house i/c necessary installation for supply of water in the houses as per approval accorded. The design of UGR along with its capacity and pump house details such as power, motor details and others shall be as per the CPWD specifications.
12. The work shall be executed as per approval accorded by local authority and the design and drawings by Competent Authority, shall be final and binding on the agency and will not be open to questions.

B. SPECIFICATION FOR SEWERAGE:

The work shall be executed as per approval accorded by local authority and the design and drawings by Competent Authority, shall be final and binding on the agency and will not be open to questions. This work shall include excavation in all stratas, laying stone ware, RCC, NP2/NP3, S&S pipes, construction of manholes, providing SFRC manhole covers, frames, heavy duty, foot rests with necessary brick work in cement mortar, plaster, bed concrete and concrete up to haunches and around the pipes wherever required.

GENERAL:

1. Circular Manholes:
 - a) Manholes shall be provided:
 - (i) At starting point of each line,
 - (ii) At all change points,
(Gradient, size of the pipe, alignment)
 - (iii) At all junction points of two or more lines. Manholes should be so spaced that each properly discharged in the direction of flow, and maximum centre to centre spacing of manholes will be as per prevailing Bye-laws.

2. Sizes of manholes:

S.No.	For depth of manhole between	Bottom diameter of manhole
1.	0.914 m to 1.68 m (3'-0" to 5'-6")	0.914 m (3'-0")
2.	1.68 m to 2.28 m (5'-6" to 7'-6")	1.220 m (4'-0")
3.	Beyond 2.28m (3'-0" to 5'-6")	1.520 m (5'-0")

- c) For depth less than 0.914 m, rectangular manholes of size 90x80 cm shall be provided.
3. The circular manholes shall be of minimum depth of 0.914m.
4. The depth of the manhole shall be taken as vertical distance between top level of SFRC cover and invert level of channel in the manhole. The work includes excavation in all types of soils for construction of manholes complete with orange colour safety foot rest of minimum 6mm thick plastic encapsulated as per IS:10910.
5. All manholes to be plastered both inside and outside with cement mortar 1:4 (1 cement: 4 coarse sand) with a floating coat of neat cement inside.
6. When sewer is being laid under sub-soil water 15cm thick stone soiling shall be provided under concrete bedding and 23cm thick under manholes.
7. Heavy duty SFRC manhole frames and covers 560mm internal dia. will be provided weighing 182 Kg. and to be tested as per IS:1726 (Part-I) for heavy duty loads. The covers shall be embossed with its year of manufacture and work 'SEWER' and IS Mark.
8. Drop Connection: Normally, no sewer line shall have a drop of more than 0.610 mtr. in any case. Wherever, the drop is more, a drop connection arrangement shall be provided as per sketch in CPWD Specification 1996, with amendments till date.

9. Pipes: Laying of sewerage lines shall include excavation in all types of soils, providing and laying of RCC, S&S pipes, NP2/NP3 as specified with rubber ring joints, testing and refilling etc., the completion of job to the satisfaction of Competent Authority and according to the specifications prescribed.
- (i) The S&S, RCC, NP-2/NP-3 pipes as per requirement / approved scheme IS marked will be used, with rubber ring and cement mortar joints.
 - (ii) Pipes laid at a depth less than 0.910m under road berms and green belts, and more than 4.57m shall be encased with 1:4:8 (1 cement : 4 fine sand : 8 graded stone agg. 40mm nominal size) cement concrete 15cm thick on all sides including under the pipes.
 - (iii) Extra excavation of at least 0.23m width in each side will be done for proper jointing of pipes at the location of sockets.
 - (iv) No sewer line shall be laid within a distance of 3.25m from building line - in case of roads. In case of service lanes / roads the sewer line shall be laid at centre of the lanes.
 - (v) The minimum size of pipe to be used shall be as per approved scheme.
 - (vi) In case the pipe are laid under sub-soil water level, the encasement shall be done with 1:3:6 (1 cement: 3 coarse sand: 6 graded stone agg. 40mm nominal size) instead of CC 1:4:8.
 - (vii) In other cases 0.15m bed encasement with 1:4:8 (1 cement : 4 fine sand : 8 graded stone agg. 40mm nominal size) cement concrete up to haunches of pipes shall be provided, the stone ballast shall be of 40mm nominal size for bed concrete and 20mm nominal size for around encasement of pipe. Where cushion is less than 0.90m around encasement of pipe with same mix will be done.
 - (i) Where the invert level of the manhole is 1.22m or more below the subsoil water level, 0.115m thick core of CC 1:2:4 (1 cement : 2 coarse sand : 4 graded stone ballast 20mm nominal size) shall be provided in the walls of the manhole upto 0.61m above sub-soil water level in order to prevent in-filtration of sub-soil water level, from the sides of the manhole shall be provided with 15cm thick 1:2:4 (1 cement : 2 coarse sand : 4 stone agg. 20mm nominal size) RCC slab, monolithically with the core of the wall of the manhole lean concrete of 1:5:10 (1 cement : 5 fine sand : 10 graded stone agg. 40mm nominal size) of 0.075m thick shall be provided under the slab.
10. Tests: The sewer line laid will be subject of following three tests:

- a) Smoke Test: To check the air tightness of joints.
- b) Mirror Test: To check the straight alignment of pipes.
- c) Disc Test: To see that lines are free of dead/set concrete/mortar/other blockages and lines laid are in straight line from manhole to manhole.

11. Any other tests, if required during course of execution will be decided by the Competent Authority and will be binding on the agency.

NOTE: Nothing extra is to be paid to the agency for testing of pipes etc.

12. The agency will submit to Competent Authority adequate sets of completion plan of sewerage system laid showing position of manholes with its centre to centre distance dia. of lines, gradients, location of drop connections, connecting point with ground levels and invert levels at each point within 10 days of completion of the sewerage work. The service plan (in original) approved by the local body along with their forwarding letter be also submitted to the Competent Authority.

13. The following stops shall be maintained while laying the pipes:

<u>S. No.</u>	<u>Dia. of Pipe</u>	<u>Slope</u>
1.	250mm	1 in 190
2.	300mm	1 in 245
3.	350mm	1 in 300
4.	400mm	1 in 360
5.	450mm	1 in 510
6.	500mm	1 in 590

14. Crossing over nallahs shall be done by C.I. pipe with necessary support.

15. The conditions mentioned in the approved scheme of local authority shall be followed strictly.

C. SPECIFICATIONS FOR STORM WATER DRAINAGE:

C/o storm water drainage shall include excavating in all types of soils, providing and laying brick work with FPS bricks of CD-75 in CM 1:4 (1 cement : 4 coarse sand). Plastering of inside and top of both walls of drain shall be in CM 1:3 (1 cement : 3 fine sand) with floating coat of neat cement and outside plastering 6” in depth both side, CC 1:5:10 (with coarse sand) in bottom & CC 1:2:4 in channel of drain then covering of all drains with SFRC covers of design mix M-25.

Following specifications will be used for providing underground pipe drainage in the complex.

- 1. The work will be executed as per the design and layout approved by the local municipal authority.
- 2. FPS bricks of CD-75 shall be used.

3. Minimum width of the drains shall be 230mm or as per CPWD specifications.
4. SFRC covers of design mix M-25 shall be provided on all the drains.
5. Any other details, if required during course of execution will be decided by the Competent Authority and will be binding on the agency.

D. SPECIFICATIONS FOR ROADS, PARKINGS & PATHWAYS:

1. Construction of internal approach roads and parking's will be done as per layout plan and standard laid down by local municipal authority. The agency will ensure that roads are developed to the full right of way. The required metalled width will be provided to the exact crust thickness as per norms. The agency will ensure that nowhere the right of way of roads reduces. The roads will be laid to camber longitudinal as well as cross-section wise.

The job of construction of roads consists of preparation of sub-grade, consolidation of the same, filling and compacting the earth work in embankment under optimum moisture conditions to give at least 95% of the maximum dry density (proctor density), supplying locally available stone and screening of blue texture of the required laying of base and sub-base courses using binding and blinding material and necessary rolling as per specification, brick on edge and pre-mixing etc. The surface dressing of the berms of roads will be done in such a fashion so as to discharge the rain water of the open areas to the storm water pipe drainage. MORTH guidelines will be followed in case of any omissions.

2. Surface dressing of the berms with slope towards drainage system.
3. CC 1:2:4 (1 cement : 2 coarse sand : 4 graded stone agg. 20mm nominal size) pre-cast kerb stone fair face finish in uniform colour, of 0.30m long and 0.20m x 0.20m section as per CPWD Specifications / direction of Competent Authority jointed with the mix 1:2 (1 cement : 2 fine sand) to be provided as per architectural drawings.
4. Toe walls in brick masonry with bricks of class designation 75 in cement mix 1:4 for pavements/footpaths wherever necessary.
5. RCC NP2 S&S pipe joints in rubber rings and cement mortar 1:2 (1 cement : 2 fine sand) for cross drainage with gully chambers of size 50x45x60cms with M.S. grating of size 500x450mm wherever necessary as per decision of the Competent Authority.
6. Any other details that crop up depending upon site conditions will be decided by the Competent Authority and will be binding on the agencies.

7. The specifications of CC pavement/footpath shall be as under:
 - a) 100mm thick CC 1:5:10 (1 cement: 5 fine sand: 10 graded stone agg. 40mm nominal size)
 - b) 100mm thick CC 1:2:4 (1 cement: 2 coarse sand: 4 graded stone agg. 20mm nominal size) over under layer of CC 1:5:10 as per para 'a' above.
 - c) Toe wall brick masonry with FPS bricks of class designation 75 in cement mortar 1:4 (1 cement: 4 coarse sand) to retain the edge of the paving.
8. The work will be done as per CPWD Specifications 2009 Vol. I & II with upto date corrections. Any other width of road as per approved development plan shall be as per prevailing norms.
9. The agency shall submit to the Competent Authority, adequate sets of completion plans for roads, paths after its completion showing right of way of each road/path and their respective cross section within 10 days of completion of road/path work.

SECTION-D

PAYMENT – SCHEDULE

- 1.0 All running /intermediate & final payments shall be made to the agency in accordance with the following schedule:
- 2.0 The basis of payment on “Pro rate basis” shall be worked out on the percentage of work done out of total scope of work

Sl. No	Activity	% payable
1.	Investigation, planning, Designing and obtaining approvals (1% of total quoted rate)	
1A	Submission of Inception Report, detailed survey, Architectural drawings ready for submission for approval of local bodies	
1B	On approval of local bodies, EIA clearances and other statutory approvals of local bodies, final Architectural drawing showing electrical and sanitary layout plan and drawings and its submission	
1C	On submission and approval of Vetted structural design by Competent Authority	
	On completion of above	1.0 %
2.	On completion of following:	
2A	Completion of excavation work, laying of foundation and reaching plinth level of all towers	10 %
2B	Completion of Super structure-Structural skeleton of external walls, slabs and other structural members, lift shaft and staircase well, etc. of residential and non-residential buildings/ towers	25.0%
2C	Internal work of residential and non-residential units with all Civil including flooring and skirting, dado-work, Electrical, Mechanical services, Plumbing	10.0%
2D	Finishing of Doors, Windows and wood work in wardrobes and complete kitchen work including all fittings and painting etc.	02.5 %
2E	Internal Finishing and painting inside residential and non-residential buildings	02.5 %
2F	External Finish and painting outside residential and non-residential buildings	02.5 %
2G	Over Head tanks, china-ware and sanitary fittings including testing etc.	02.5 %
2H	Electrical Installation including external electrification, installation of distribution boards, laying off cables, installation of electric sub-station and other associated electrical works etc.	02.5 %

	Installation of Lifts and machine room	02.5%
	Fire Fighting System	04.0%
	External Infrastructure outside residential buildings and within boundary wall including water supply, sewerage including STP/ septic tank, sewer line, inspection chambers, electricity lines, storm water drainage, rain water harvesting, solid waste management, signages, installation of solar street lights and other associated worksetc.	15.0%
	Site Development works including Horticulture Services, development of parks and green areas, Tot-lots, street furniture, construction of boundary wall and installation of gates, internal roads, Street lighting, other amenities etc.	10.0%
	On issuing of Completion Certificate by competent authority and after taking all statutory approvals from local authorities	10.0%

SECTION-E

PART -1

Financial Quote

SCHEDULE OF QUANTITIES

Name of Work:

S. No	Description of Item	Quantity (No. of Houses)	Units	Rate in Rs.		Amount Rs.
				In Figure	In Words	
1	Construction of 1024 EWS units at LHP site at Indore, Madhya Pradesh including all associated facilities and services, development works complete as per scope of work, drawings attached with this document and directions of Competent Authority.	A		B		A x B
			L.S.			
2	Cost of Infrastructure Lumpsum for site specific as per RFP		L.S.			
	Grand Total					

Note:

- a) All participating agencies are advised to quote the rates in financial bids for both the items and L1 will be declared after getting the comprehensive rates for S.No. 1 and 2 otherwise, bids will be considered as non-responsive and will be rejected without assigning any reasons.
- b) If any participating agency is quoting for more than one location with same or different technology, then the agency is required to quote separately for different locations as well as for different technologies.
- c) Per unit rate of EWS house will be derived from lumpsum figure and calculations will be made for computation of total cost in case of number of EWS houses constructed get increase or decrease

SECTION-E

PART -2

Financial Quote

SCHEDULE OF QUANTITIES

Name of Work:

S. No	Description of Item	Quantity (No. of Houses)	Units	Rate in Rs.		Amount Rs.
				In Figure	In Words	
1	Construction of 1144 EWS units at LHP site at Rajkot, Gujarat including all associated facilities and services, development works complete as per scope of work, drawings attached with this document and directions of Competent Authority.	A		B		A x B
			L.S.			
2	Cost of Infrastructure Lumpsum for site specific as per RFP		L.S.			
	Grand Total					

Note:

- a) All participating agencies are advised to quote the rates in financial bids for both the items and L1 will be declared after getting the comprehensive rates for S.No. 1 and 2 otherwise, bids will be considered as non-responsive and will be rejected without assigning any reasons.
- b) If any participating agency is quoting for more than one location with same or different technology, then the agency is required to quote separately for different locations as well as for different technologies.
- c) Per unit rate of EWS house will be derived from lumpsum figure and calculations will be made for computation of total cost in case of number of EWS houses constructed get increase or decrease

SECTION-E

PART -3

Financial Quote

SCHEDULE OF QUANTITIES

Name of Work:

S. No	Description of Item	Quantity (No. of Houses)	Units	Rate in Rs.		Amount Rs.
				In Figure	In Words	
1	Construction of 1152 EWS units at LHP site at Chennai, Tamil Nadu including all associated facilities and services, development works complete as per scope of work, drawings attached with this document and directions of Competent Authority.	A	L.S.	B		A x B
2	Cost of Infrastructure Lumpsum for site specific as per RFP		L.S.			
Grand Total						

Note:

- a) All participating agencies are advised to quote the rates in financial bids for both the items and L1 will be declared after getting the comprehensive rates for S.No. 1 and 2 otherwise, bids will be considered as non-responsive and will be rejected without assigning any reasons.
- b) If any participating agency is quoting for more than one location with same or different technology, then the agency is required to quote separately for different locations as well as for different technologies.
- c) Per unit rate of EWS house will be derived from lumpsum figure and calculations will be made for computation of total cost in case of number of EWS houses constructed get increase or decrease

SECTION-E

PART -4

Financial Quote

SCHEDULE OF QUANTITIES

Name of Work:

S. No	Description of Item	Quantity (No. of Houses)	Units	Rate in Rs.		Amount Rs.
				In Figure	In Words	
1	Construction of 1008 EWS units at LHP site at Ranchi, Jharkhand including all associated facilities and services, development works complete as per scope of work, drawings attached with this document and directions of Competent Authority.	A	L.S.	B		A x B
2	Cost of Infrastructure Lumpsum for site specific as per RFP		L.S.			
	Grand Total					

Note:

- a) All participating agencies are advised to quote the rates in financial bids for both the items and L1 will be declared after getting the comprehensive rates for S.No. 1 and 2 otherwise, bids will be considered as non-responsive and will be rejected without assigning any reasons.
- b) If any participating agency is quoting for more than one location with same or different technology, then the agency is required to quote separately for different locations as well as for different technologies.
- c) Per unit rate of EWS house will be derived from lumpsum figure and calculations will be made for computation of total cost in case of number of EWS houses constructed get increase or decrease

SECTION-E

PART -5

Financial Quote

SCHEDULE OF QUANTITIES

Name of Work:

S. No	Description of Item	Quantity (No. of Houses)	Units	Rate in Rs.		Amount Rs.
				In Figure	In Words	
1	Construction of 1000 EWS units at LHP site at Tripura, Agartala including all associated facilities and services, development works complete as per scope of work, drawings attached with this document and directions of Competent Authority.	A		B		A x B
			L.S.			
2	Cost of Infrastructure Lumpsum for site specific as per RFP		L.S.			
	Grand Total					

Note:

- a) All participating agencies are advised to quote the rates in financial bids for both the items and L1 will be declared after getting the comprehensive rates for S.No. 1 and 2 otherwise, bids will be considered as non-responsive and will be rejected without assigning any reasons.
- b) If any participating agency is quoting for more than one location with same or different technology, then the agency is required to quote separately for different locations as well as for different technologies.
- c) Per unit rate of EWS house will be derived from lumpsum figure and calculations will be made for computation of total cost in case of number of EWS houses constructed get increase or decrease

SECTION-E

PART -6

Financial Quote

SCHEDULE OF QUANTITIES

Name of Work:

S. No	Description of Item	Quantity (No. of Houses)	Units	Rate in Rs.		Amount Rs.
				In Figure	In Words	
1	Construction of 1040 EWS units at LHP site at Lucknow, Uttar Pradesh including all associated facilities and services, development works complete as per scope of work, drawings attached with this document and directions of Competent Authority.	A	L.S.	B		A x B
2	Cost of Infrastructure Lumpsum for site specific as per RFP		L.S.			
	Grand Total					

Note:

- a) All participating agencies are advised to quote the rates in financial bids for both the items and L1 will be declared after getting the comprehensive rates for S.No. 1 and 2 otherwise, bids will be considered as non-responsive and will be rejected without assigning any reasons.
- b) If any participating agency is quoting for more than one location with same or different technology, then the agency is required to quote separately for different locations as well as for different technologies.
- c) Per unit rate of EWS house will be derived from lumpsum figure and calculations will be made for computation of total cost in case of number of EWS houses constructed get increase or decrease

SECTION-F

DETAILED TECHNICAL SPECIFICATIONS OF SHORTLISTED PROVEN TECHNOLOGIES

2.1 Precast Concrete Construction System - 3D Precast Volumetric

(1. M/s Katterra India Private Limited, 2. M/s Moducast Pvt. Ltd., 3. M/s Magicrete Building Solutions, 4. M/s Ultratech Cement Ltd.)

1. Manufacturing of 3D Volumetric Components

Fabrication and manufacturing of solid precast concrete modules (room, toilet ,kitchen, bathroom, stairs etc) through 3D volumetric casting or structural modules cast in Plant/Casting yard assembled together through casting of wall and floor panels. Modules shall be manufactured in controlled factory environment with approved methodology including moulds, mixing, transporting and placing of concrete, vibrating, curing, finishing, making necessary cutout/holes of required sizes for services, yard handling & stacking all complete as per approved shop drawings and design mix as per the direction of Engineer-in-Charge.

2. Transportation of Modules

Transportation of Precast Elements by flat bed Tractor (Double / Triple axle 40ft Length with proper accessories like A frame etc) from factory, including loading, unloading & stacking at site with the help of required capacity cranes.

3. Erection & Installation of Modules

Erection & Installation of Precast Concrete modules in correct & final position with proper line level and plumb at site making all arrangements (i.e cranes, push-pull jacks & all another T & P for lifting Placing & Alignment of elements, within erection tolerance as per IS 15916 (Building Design and Erection Using Prefabricated Concrete - Code of Practice) shall be as per approved shop drawings and all complete as per the direction of Engineer-in-Charge including all accessories, jointing, grouting complete. The structure shall be complete in all respect with all internal and external finishing as per approved drawings.

All relevant Indian Standards/ requirement of NBC shall be conformed for designing, casting , prefabrication ,erection and installation.

2.2. Pre-cast Concrete construction System -Pre-Cast components assembled at Site

(1. M/s Larsen & Toubro, 2. M/s B.G. Shirke Construction Technology Pvt. Ltd., 3. M/s Elematic India , 4. M/s PG Setty Construction Technology Pvt. Ltd. 5. M/s Teemage Builders Pvt. Ltd. 6. M/s Nordicflex House 7. M/s Adlakh Associates Pvt. Ltd. 8. M/s William Ling)

1. Manufacturing of Solid Pre-cast concrete Elements

Solid precast concrete elements shall be fabricated and manufactured with provisions of shear keys, connecting loops, dowel tubes and proper lifting accessories for walls, beams, slabs, stairs, column etc, of various thickness, shape and size of different concrete grades manufactured in controlled factory environment with approved methodology including moulds (Pallet system, Tilts form, table moulds, battery moulds, vertical moulds, beam moulds, column moulds, staircase moulds, Facade mould, etc.), mixing, transporting and placing of concrete, vibrating, curing, finishing, making necessary cutout/holes of required sizes for services, yard handling & stacking all complete as per IS 11447:1985 (Code of practice for construction with large panel prefabricates) and as per approved shop drawings and design mix as per the direction of Engineer-in-Charge. Minimum grade of Concrete for solid structural components shall be M-35.

2. Manufacturing of Pre-stressed Hollow core Slab

Pre-stressed Hollow Core slab (Hollow area 25 to 30%) of different thickness & modular width 1200 mm shall be fabricated & manufactured in controlled Factory Environment with approved methodology by using long line casting method having arrangement of proper steel bed. Concreting should be done by batch mixing plant capable of producing zero slump concrete, transported through automatic shuttles of standard make & layed on bed with the help of extruder/Slip former, finishing, curing and also provision of steam curing. Cutting, making necessary cutout/holes of required sizes for services in slab element after achieving required strength, yard handling & stacking all complete as per approved shop drawings & design mix as per the direction of the Engineer-in-charge. Minimum grade of Concrete for pre-stressed hollow slab is to be M-40.

Pre-stressing steel strands (low relaxation) shall be provided & laid in position on hollow core bed by using mechanical pulling arrangement like Rabbit/ Bed master including all accessories for Stressing & de-stressing operations as per approved make conforming to IS1343 (Pre-stressed Concrete — Code of Practice) & grade FY-1860 etc, complete as per drawings and direction of Engineer -in-charge.

All relevant Indian Standards/ requirement of NBC shall be confirmed.

3. Transportation of Pre-cast elements

Transportation of Precast Elements by flat bed Trailer (Double / Triple axle 40ft Length with proper accessories like A frame etc) from factory, including loading, unloading & stacking at site with the help of required capacity cranes.

4. Erection & Installation of Pre-cast elements

Precast/Pre-stressed Concrete elements shall be erected & Installed in correct & final position with proper line level and plumb at site making all arrangements

(i.e cranes, push-pull jacks & all another T & P for lifting placing & alignment of elements, within erection tolerance as per IS 15916 as per approved shop drawings and all complete as per the direction of Engineer-in-Charge

Weather proof sealant shall be applied on outer joints of approved make confirming to relevant Indian Standard.

Leveling sim pads of required sizes (5x5cm to 10x10cm) of PVC / Rubber to adjust level of bearing surface of supporting members shall be applied.

Grouting of dowel tubes / Shear keys / Joints of precast members with M-60 grade cementations grout (Non Shrink) of approved make by suitable means (Free flowing /pump) shall be done including curing etc.

2.3 Light Gauge Steel Structural System & Pre Engineered Steel Structural System

2.3.1 Light Gauge Steel Structural System

(1. M/s Mitsumi Housing Pvt. Ltd., 2. M/s Everest Industries Ltd., 3. M/s JSW Steel Ltd., 4. Society for Development of Composites, 5. Elemente Designer Home 6. M/s MGI Infra Pvt. Ltd., 7. M/s RCM Prefab Pvt. Ltd., 8. M/s Nipani Infra and Industries Pvt. Ltd., 9. M/s Strawture Eco, 10. M/s Visakha Industries Ltd.)

1. Fabrication & Installation of LGSF Framing Components

Designing, providing, installing and fixing factory finished custom designed cold form Light Gauge Steel Framed super structure comprising of steel wall panel, trusses, purlins etc manufactured out of minimum 0.75 mm thick steel sheet as per design requirements. The steel sheet shall be galvanized (AZ-150 gms Aluminum Zinc Alloy coated steel having yield strength 300- 550 Mpa) conforming to AISI specifications and IBC 2009 for cold formed steel framing and construction and also as per IS: 875- 1987 (Part-I; Dead Load , Part-II; Imposed load, Part-III; wind load , Part-IV; Snow load, and Part-V; Special load & load combinations), IS 800- 1984 (Code of practice for general construction in steel) and IS: 801- 1975 (Code of Practice for Use of Cold Formed Light Gauge Steel Structural Members In General Building Construction). The wind load shall be as per provisions of IS 875 (part -III). LGSFS frame shall be designed as per IS: 801 using commercially available software such as Frame CAD Pro-11.7/ STAAD PRO-V8i/ArchitekV2.5.16/ Revit architecture2011 or equivalent.

The framing section shall be cold form C-type having minimum web depth 89 mm x 39mm flange x 11mm lip in required length as per structural design requirement duly punched with dimple/slot at required locations as per approved drawings. The slots will be along centre line of webs and shall be spaced minimum 250mm away from both ends of the member. The frame can be supplied in panelized or knock down condition in specific dimensions and fastened with screws extending through the steel beyond by minimum of three exposed threads. All self drilling tapping

screws for joining the members shall have a Type II coating in accordance with ASTM B633(13) or equivalent corrosion protection of gauge 10 & 12, TPI 16 & 8 of length 20mm. The frames shall be fixed to RCC slab or Tie beam over Neoprene rubber using self expanding carbon steel anchor bolt of dia as per approved drawings, design subject to minimum 12mm diameter and 121mm length conforming to AISI 304 and 316 at 500mm c/c with minimum embedment of 100mm in RCC and located not more than 300mm from corners or termination of bottom tracks complete in all respects.

Hot rolled Steel sections as per design & conforming to IS 800 can be used for buildings higher than G+3.

2. Connections

Proper usage of Connection Accessories like Heavy duty tension Ties, Light duty Hold-ons, Twist Straps (to connect truss with wall frames), Strong Tie, Tie Rod, H-Brackets, Boxing Sections, L-Shaped Angles shall be ensured for required structural integrity & stability.

3. Walling Components

Walling with Fiber Cement board & Gypsum plaster board

Providing and fixing of external wall system on Light gauge steel frame work with outer face having 6mm thick heavy duty fiber cement board fixed on 9mm thick heavy duty fiber cement board confirming to IS 14862:2000, category IV type A (High pressure steam cured) as per standard sizes fixed with self-drilling / tapping screws / fasteners @ 60cm c/c of approved make. A groove of 2 mm to 3mm shall be maintained and grooves shall be sealed with silicon based sealant.

The board shall be fixed in a staggered pattern. Screws shall be of outer sunk rib head of 1.60mm to 4 mm thick of 8 to 10 gauge of length varying from 25 to 45 mm and internal face 12.5mm thick gypsum plaster board fixed on 8mm thick fiber cement board confirming to IS 14862:2000 of category III type B (High pressure steam cured) as per standard sizes fixed with self-drilling / tapping screws / fasteners @ 60cm c/c of approved make, proper tapping and jointing to be done using fiber mesh tape and epoxy and acrylic based jointing compound for seamless finish.

A breathable vapour barrier underneath the cement fiber board as per National Building Code 2009 is to be provided complete as per direction of Engineer-in-charge.

Any other suitable in-fill walling materials can be used in the system, however it shall be such that the completed wall provides fire resistant & other properties as per the requirements given in National Building Code 2016.

4. Floor/ Slab

RCC floor/ roof slab as per design conforming IS 456 over deck sheet shall be provided. The thickness and profile of decking sheet shall be verified with the erection drawings. These are normally used as temporary supports for the concrete till hardens. Decking sheet has to be screwed to the joist with maximum spacing of 600 mm c/c for uniform action of concrete and joist. All the joints of decking sheets longitudinal direction require a minimum lap of 100 mm.

2.3.2 Pre-Engineered Steel Structural System (PEB) (1. M/s RCC Infra Ventures Ltd.)

Pre-engineered Building (PEB) shall be of structural steel construction with columns, rafters, beams etc. as per design & conforming to and walls shall be of Autoclaved Aerated Concrete (AAC) blocks of approved composition, size and strength. Building shall be designed, manufactured, supplied and erected by the agency. The structural design shall be done as per the prevailing Indian standards and conforming to NBC 2016. Floor/roof slab shall be of RCC as per approved structural design. The structure will be complete in all respect with all plumbing, sanitary, electrical installations, painting and finishing as per approved drawings.

2.3.3. Pre-Engineered Steel Structural System (PEB) with speed floor system (1. M/s Jindal Steel & Power Ltd.)

Pre-engineered Building (PEB) shall be of structural steel construction with columns, rafters, beams etc. and walls shall be of Autoclaved Aerated Concrete (AAC) blocks of approved composition, size and strength. Building shall be designed, manufactured, supplied and erected by the agency. The structural design shall be done as per the prevailing Indian standards and conforming to NBC 2016. Floor/roof slab shall be of Speed Floor system which is a suspended concrete flooring system using a roll formed steel joist as an integral part of the final concrete and steel composite floor as per approved structural design. The Speed floor system is a hybrid concrete/steel tee-beam in one direction and an integrated continuous one-way slab in other direction. The joists of different depths are manufactured from pre- galvanized high tensile steel. The joist depth and the concrete thickness are varied depending on the span, imposed loads and other functional considerations. The structure will be complete in all respect with all plumbing, sanitary, electrical installations, painting and finishing as per approved drawings.

2.3.4 Aerated Cement Concrete Panel System with Steel Structural Framing System

- (1. M/s HIL Ltd.,
- (2. M/s Biltech Building Elements Ltd.,
- (3. M/s SCG International India Pvt. Ltd.)

1. Manufacturing & Fixing of Aerated Concrete Panel

Providing and fixing in position factory made non asbestos fibre reinforced aerated cement sandwich wall/roof/floor light weight solid core panels made of light weight cement concrete core composed of OPC cement, pulverized fly-ash, quick lime, cotton pulp & Gypsum in mortar state mixed with aeration agent in a preset mould. The outer face on both sides of the panels shall be non asbestos fiber cement board conforming to IS 14862:2000. These solid wall panels shall be installed using Galvanized iron steel tracks/C channel of 1mm thick of required sizes as recommended by manufacturer's and fixed to floor and RCC/ steel soffit in plumb to each other with steel screw/fasteners. The panel shall be fixed vertically with tongue & groove joint with cement based polymer modified jointing compound. The exposed surface finished with fiber mesh/glass fiber tape with polymer based jointing compound having superior flexibility. Panels should be used as floor & roofing with additional structural support, steel or RCC depending upon the design. All the operation shall be completed in all respect as per drawings, Manufacturers specifications and under the overall direction of Engineer-in-Charge

2. Steel Structural Framing System

Steel structure frame as per design & conforming to IS: 800 shall be used in the construction. Steel tracks/ C channels as per manufacturer's specification should be used to hold the panels with the structure firmly. All jointing need to ensure required structural stability & integrity.

All relevant Indian Standards/ requirements of NBC shall be conformed.

2.3.5 Pre-Cast Light Weight Hollow core wall panel (1. M/s Pioneer Precast Solutions Pvt. Ltd.)

1. Manufacture of Hollow Core Panel

Construction using "Hollow Core light weight concrete non-load bearing wall panels manufactured in controlled factory conditions using battery moulds, light weight concrete (density 675 to 750 kg/m³) and other additives as per manufacturer's specification. Panels are pre-cured naturally for 12-24 hrs and then water cured for seven days before installation. Panels are provided with tongue and groove joints for easy assembly. Panels are Battery mould panels. Panels are produced in standard widths & thickness and in lengths suitable to room height. Standard width is 611 mm, height 2900 and thickness 65 mm, 80 & 100mm. Panels shall conform to tolerances w.r.t. Length : + 3mm, Width : + 2mm, Thickness : + 1mm, Squareness of end : +3mm. The structure will be complete in all respect with all plumbing, sanitary, electrical installations, painting and finishing as per approved drawings.

2. Structure Framing Section & Connection

Being non-load bearing, these panels are used with structural steel frame designed as per relevant Indian Standards and conforming to NBC 2016. The connection to framing section shall ensure required structural integrity & stability.

3. Floor/ Roof slab

RCC floor/ roof slab as per design conforming IS 456 over deck sheet shall be provided. The thickness and profile of decking sheet shall be verified with the erection drawings. Decking sheet has to be screwed to the joist with maximum spacing of 600 mm c/c for uniform action of concrete and joist. All the joints of decking sheets longitudinal direction require a minimum lap of 100 mm.

All relevant Indian Standards/ requirement of NBC shall be conformed.

2.4 Prefabricated Sandwich Panel System

2.4.1 Reinforced Expanded Polystyrene Core Panel System (1. M/s Worldhaus, 2. M/s Bau Panel Systems India Pvt Ltd, 3. M/s BK Chemtech Engineering, 4. M/s MSN Construction, 5. M/s Beardshell Ltd.)

The technical specifications would be entirely based on design parameters, however, the minimum specification as given below is recommended to be adhered to;

1. Specifications of Raw Materials for EPS Panel

- i) Zinc Coated cold drawn Steel Wire – Shall be of 2.5/3.0 mm dia and zinc coating galvanizing shall be of 60 gm/m² ± 5 gm/m²

Mechanical characteristics

Yield stress	: > 600 N/mm ²
Breaking load	: > 680 N/mm ²
Elongation	: > 8%

Chemical characteristics

% C	: < 0.24
% P	: < 0.055
% S	: < 0.055
% Ceq	: < 0.52

- ii) Expanded Polystyrene – Self-extinguishing type EPS 80 in accordance to UNI EN 13163:2013 (IS 4671: 1984) having density not less than 15 kg/m³

2. EPS Panels for wall

Walling shall be completed using factory made Expanded Polystyrene Core Panel (EPS) based electro welded wire mesh 3D panels manufactured using the specified EPS and Cold drawn wire and sprayed structural plaster. The specification of panel shall not be less than the values given in **fig. 1 & 2** below. Both the outer faces of the panel shall be finished by applying the layer of minimum 35 mm thick cement mortar 1:3 {1 cement: 3 coarse sand (not having more than 40% stone chips of size upto 6 mm)}; with the help of shotcreting / guniting equipment etc at a pressure not less than 1 bar (100Kn/m²) and both surfaces finished with trowel. The composition of spray/ mortar shall be such as to give minimum characteristic strength of 25 N/mm². The maximum w/c ratio shall be 0.45. The thickness of the sprayed concrete & EPS wall shall be based on design requirements.

Single panel for structural uses

Longitudinal wire	Min 2.5 mm ϕ spaced @ 70 mm (Max.)	<p>Typical Drawing</p>
Transverse wire	Min 2.5 mm ϕ spaced @ 70 mm (Max.)	
Cross steel wire	Min 3.0 mm ϕ approx 68 nos. / m ²	
polystyrene Core	Density >15 Kg/m ³ , Thickness not less than 80 mm	
Finished Masonry	Not less than 150 mm thick	
Grade of Shotcrete	Minimum M-25	

Fig.1

Single panel for internal partition and insulation

Longitudinal wire	Min 2.5 mm spaced @ 8 mm (Max.)	 <p>Typical Drawing</p>
Transverse wire	Min 2.5 mm spaced @ 7 mm (Max.)	
Cross steel wire	3.0 mm approx 45 nos / m ²	
polystyrene Core	Density > 1 Kg/m ³ , Thickness 4 mm to 320 mm	
Finished Masonry	Min 90 mm	

Fig2

3. Staircase panel

The EPS panel based staircase would be preferred as per minimum specification given in **Fig.3**. However, the Agency can propose for construction of staircase in RCC or steel frame based staircase for approach on all floors up to terrace floor. The concrete thickness shall be as per as per design requirement & spary/mortar shall be minimum 30 mm.

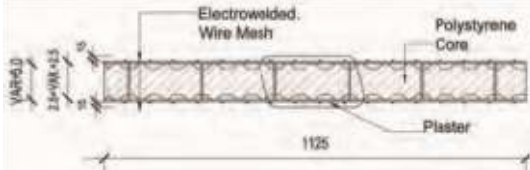
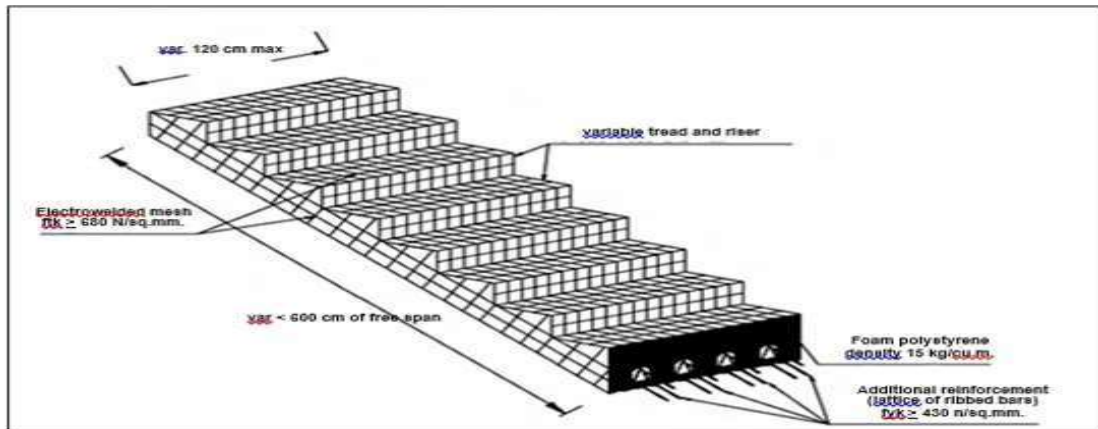

Galvanized steel wire mesh:

- Longitudinal wires: 2.5 mm dia
- Transversal wires: 2.5 mm dia
- Cross steel wire: 3.0 mm dia
- Polystyrene slab density: > 15 kg/m³

Fig 3

4. Flooring & Roofing

Intermediate floor shall be composite EPS as per specification and shall be designed for combined effect of dead load, imposed load & other loading conditions. The specification of panel shall not be less than the values given in **fig. 4** below

Single Panel for horizontal structure for floor/ roof

Longitudinal wire	Min 2.5 mm ϕ spaced @ 80 mm	
Transverse wire	Min 2.5 mm ϕ spaced @ 75 mm	
Cross steel wire	Min 3.0 mm ϕ approx 68 nos. / m ²	
polystyrene Core	Density Min 15 Kg/m ³ Thickness Min 80 mm	
Finished Masonry	Min 160 mm thick	
Grade of Shotcrete/ concrete	Min M-25	

Floor panel with reinforcement at joist

Longitudinal wire	Min 2.5 mm ϕ spaced @ 80 mm	
Transverse wire	Min 2.5 mm spaced @ 70 mm	
Cross steel wire	Min 3.0 mm ϕ approx. 68 nos. / m ²	
polystyrene Core	Density > 15 kg/m ³	

a = thickness of core; b = thickness of concrete; c = overall thickness

The Panels to be used for the floor and the roof system and reinforced in the joists with concrete casting on the site. The reinforcement of the panel can be integrated during the panel assembly by additional reinforcing bars inside the joists as per the design.

Fig.4

5. Connections;

Jointing of the panels shall be ensured in such a way to make it safe from vertical load, lateral loads and impact loads & to provide required structural integrity & stability. Jointing shall be sealed properly.

2.4.2 EPS Cement Sandwich Panel System

(1. M/s Bhargav Infrastructure Pvt.Ltd, 2. M/s Rising Japan Infra Private Limited)

1. Manufacturing & Fixing of EPS (Beads) based Cement Panel

Providing and fixing in position factory made EPS cement sandwich wall/roof/floorlight weight solid core panels made of core material of EPS granule balls/beads(conforming to IS 4671:1984 and shall have density not less than 15kg per cum)adhesive, cement, sand, flyash and other bonding material in mortar state processed to form in a preset mould. The outer face on both sides of the panels shall be nonasbestos fiber cement board conforming to IS 14862:2000 or Calcium silicate board conforming to EN 14306:2009 of 5mm thick each. Panel shall be laid on 6mm thick cement mortar (1 cement: 2 fine sand) mixed with chemical adhesive of 0.5kg per50kg of cement or shall be preferably fixed into 'C' channel made of 1.2mm thick MS plate screwed/ fastened to the slab/column/beam etc. The panel shall fixed vertically with tongue and groove joint and horizontally locked with steel bar between each other and floors and filled with cement mortar and adhesive. Panels should be used as floor & roofing with additional structural support, steel or RCC depending upon the design. All the operation shall be completed in all respect as per drawings, manufacturers specifications and under the overall direction of Engineer-in-Charge

2. Steel Structural System

Steel structure frame as per design & conforming to IS: 800 shall be used in the construction. U type channels as per manufacturer's specification should be used to hold the panels with the structure. Additional clips may be welded with the frame pillars and beams to hold

the U channel firmly with the pillars/beams and floor, to ensure structural integrity. PU glue may be applied to hold the panels firmly.

All relevant Indian Standards/ requirements of NBC shall be conformed for materials, design ,fabrication and erection.

2.4.3 Pre-fab PIR (Polyisocyanurate) based Dry Wall Panel System (1. M/s Covestro India Pvt. Ltd.)

1. PIR Dry Wall Pre-Fab Panel raw material & Structural System

Construction with PIR Dry Wall Pre-Fab Panel non-load bearing walling system where two fiber cement boards (FCB) of 10 mm thickness shall be filled with insulation foam material namely Poly Isocyanurate (PIR) in-situ and erected to produce straight to finish walls.

Fiber Cement Board: Shall be 100% asbestos free and of Type A, Category 3 minimum. as stipulated in IS 14862:2000.(ii) Pre-painted Galvanized Iron (PPGI) sheet: Shall be 0.5mm thick and as conform to IS 14246:2013 (iii) Square Hollow Section (SHS)/C Channel: Shall be manufactured from pre-galvanized high tensile steel conforming to IS 277:2003. (iv) Fibre glass mesh: Shall be as per manufacturer specifications. (v) Acrylic based glue: Shall be as per manufacturer specifications. (vi) Galvanized MS screws: Shall be as per manufacturer specifications. (vii) Anchor fasteners: Shall be of 10mm to 12mm dia., 50mm to 75mm length and as per manufacturer specifications. (viii) Premix Putty: Shall conform to IS 419:1967.

PIR wall being non-load bearing wall panels shall be supported with Steel Structural frame members as per approved structural design & conforming to IS 800 (Code of practice for general construction in steel).

2. Erection & Installation of Components

Erection & Installation of Steel sections in correct & final position with proper line level and plumb at site making all arrangements (i.e cranes, push-pull jacks & all another T & P for lifting Placing & Alignment of elements, as per approved shop drawings and all complete as per the direction of Engineer-in-Charge including all accessories, jointing, grouting complete. The structure shall be complete in all respect with all internal and external finishing as per approved drawings.

3. Floor/Roof

In-situ RCC slab or RCC slab over deck sheet as per design & relevant code shall be provided as per approved drawing.

2.4.4 Load Bearing Insulated Sandwich Panel System for Walling & Flooring (1. M/s Project Etopia Group)

Brief of Housing System

It is proprietary 4Wall panelised construction system comprising of light weight load bearing insulated panels. The System is sustainable since the panels can be deconstructed & recycled. The system is energy positive (uses solar grids) with no carbon produced from running/operation of the building & it creates more energy than used, feeding back to main building. The system introduces daylight mimicry, creates perfect lighting environment irrespective of rain & shine condition. It has air purification system & smart control.

Specifications of the panel;

S. No.	Key Aspects of the system/panel	Values/details
1.	Strength	Structural loading strength of 825 KN/80 tonne
2.	Thermal Value	0.13 U value with light weight panel structure
3.	Structural Fire Resistance	66 minutes (40KN)
4.	Air Tightness	0.07 l/s/m ²
5.	Panel Lightness	Heaviest panel weighs 97 Kg, meaning it can easily be lifted and transported
6.	Hurricane Resistance	Can handle/withstand winds exceeding 400 Mph

Structural Requirement

The structural design calculations should clearly demonstrate structural integrity and stability including connection details. In addition, any other requirements including safety against earthquake need to be ensured by the designer as per prevailing codal requirements. All relevant Indian Standards/requirement of NBC shall be conformed.

2.5 Monolithic Concrete Construction System

(1. M/s Maini Scaffold Systems Pvt. Ltd., 2. M/s KumkangKind India Pvt. Ltd, 3. M/s S-form India Pvt. Ltd., 4. M/s ATS Infrastructure Ltd., 5. M/s Innovative housing & Infrastructure Pvt. Ltd 6. M/s MFS formwork Systems Pvt. Ltd., 7. M/s Knest Manufacturers LLP. 8. M/s Outinord Formworks Pvt. Ltd. 9. M/s Brilliant Etoile)

Aluminum Formwork System

The customized Aluminum formwork using grade 5052 aluminum with panel sheets of minimum 4 mm thick shall be used for monolithic construction of RCC members & for extruded sections grade 6061 (Type-6) aluminum shall be used. The panel sheets shall have repetitive usage of 100 times. The form work includes of beam components i.e. beam side panel, prop head for soffit beam, beams soffit panel, beam soffit bulk head and deck components i.e. deck panel,

deck prop, prop length, deck mid, soffit length, deck beam bar and wall components i.e. wall panel, rocker, kiker and internal soffit corner, external soffit corner, external corner, internal corner etc., The panels are to be held in position by pin and wedge system that passes through holes in the out side rib of each panel. The tolerance of finished panels to be (-1 mm), and shall conform to IS 14687-1999 (False work for concrete structures – Guidelines). Pins and wedges to be made of high grade mild steel.

Modular Tunnel Form Work System

The Modular Tunnel form System shall consist of inverted L- shaped half tunnels (one vertical panel and one horizontal panel) joined together to create a tunnel. These forms are to be made up of factory cut, 80mm x 80 mm angle sections in accordance with the line of building forms. The panels shall be designed based on loading requirements with minimum 3 mm hot dip galvanized steel sheet, stiffened by folded sheet metal sections. All components shall meet relevant Indian Standards.

Structural Design

The structural design of plain & RCC shall be as per IS 456:2000 while IS 13920:2016 (Ductile detailing of reinforced concrete structures subjected to seismic forces -Code of practice) is referred for ductile detailing of reinforced concrete structure. Thickness of wall below plinth level should be minimum 200 mm with double layers reinforcement. The minimum thickness of RCC wall member shall be 120 mm. All relevant Indian Standards/ requirement of NBC shall be conformed.

2.6 Stay In Place Formwork System

2.6.1 Expanded-Steel Panel reinforced with all Galvanized Steel Wire-Struts (M/s JK Structures)

Expanded-Steel Panel reinforced with all-galvanised Steel Wire-Struts serving both as the load-bearing steel structure and as the stay-in-place steel formwork filled with EPS-alleviated concrete.

Construction of monolithic structure completely “on site”, without formwork with 3D galvanized structural steel (as per manufacturer specification) panels assembled and reinforced with interlocked 3D steel studs and then injected with pumped-in and hand-finished EPS (expanded polystyrene) -alleviated concrete (as per approved mix design and manufacturer’s specification) combining in one single process a stay in place formwork with embedded columns and beams and bracing system. The EPS alleviated concrete is concrete produced with EPS beads. Erection & installation of the structure in correct & final position with proper line level and plumb at site making all necessary accessories & arrangements. per approved drawings and all complete as per the direction of Engineer-in-Charge including all accessories, jointing, grouting complete. The structure shall be complete in all respect with all internal and external finishing as per approved drawings. All relevant Indian Standards/ requirement of NBC shall be conformed

2.6.2 GFRG Panel Building System (M/s FACT RCF Building Products Limited)

1. Providing & Erecting GFRG Panels

Standard quality GFRG panel of 124 mm thickness with modular cavities procured from GFRG panel manufacturing plant in the country, cut to required wall sizes and floor/ roof slab sizes in correct length and height, including cutting of door, window and ventilator opening as per the cutting drawing prepared by architects /design engineers for the construction of GFRG building and loaded in still ages for transportation to the construction site. Panels to be unloading at site using suitable fork lift/ crane.

Erection of GFRG Panels in walls in all floors using suitable crane as per instructions of Engineer-in-Charge, as per cutting drawings and structural drawings, in perfect line and plumb, above RCC plinth beam/GFRG panel below and provide necessary lateral/ slanting support to keep the wall panel in safe position, providing & tying of Reinforcement as per structural drawings and applying a coat of water repellent coating Zycosil/equivalent or equivalent product (1 Zycosil/equivalent compound: 10 water) to saturation level over RCC plinth beam to provide water proofing treatment to joint between wall panel & plinth beam to make it sealed completely.

Note:

- i. When cutting panel, “A” side is to be for outside or external surface of respective external wall and B side is to be for internal surface of wall
- ii. Erection of panel is to be with reference to both building plan & cutting drawing by following notational mark indicated in the cutting drawing as well as notional mark written on each panel cut as per cutting drawing

2. Filling of empty cavities

Filling of empty cavities (as shown in the structural design drawing) with quarry dust mixed with 5% cement (by volume). After initial infill of 50 mm thick with M25 concrete at base/bottom of cavities to seal off, infill wall panel cavities in 3 stages as detailed below,

- i. 1st pour / infill to be limited to 0.3 to 0.50 m height from bottom of the panel.
- ii. 2nd Pour/ infill: infilling shall be done only after 90 minutes interval between successive pours. The maximum height of infill shall be restricted to 1.5m height or up to the top level of door / window.

- iii. 3rd pour/infill: After an interval of 90 minutes of second pour, infill or pour the balance height up to the bottom of embedded RCC tie beam. Pour enough water just required to dampen the dry mix enough to form cake form after each stage. (If any rain falls in between any stages of concrete pour, make sure to cover the panel top to prevent ingress of water or water falling into the cavities. In case of water collection over the concrete inside the panel, drill 10mm hole in GFRG panel immediately above concrete filled level to drain out water before pour/in-fill of balance concreting)

3. Laying of GFRG panel as roof / floor slab panel and staircase panel

Laying of GFRG panel as roof / floor slab panel and staircase panel using suitable crane as per instructions of Engineer-in-Charge, including providing support system with 25mm x 300mm-400 mm wide plywood, as runner with proper prop below proposed micro beams including

- a. Cutting of top flange of panel to 180 mm wide (leaving 25mm projection on either side) to provide RCC embedded micro beam as per cutting drawings and structural drawings.
- b. Reinforcement for micro beams and tie beams to be provided in position with proper anchorage as per structural drawings.
- c. Provision for Electrical cabling, fan hooks and laying of pipes for plumbing work.
- d. Concreting of Tie beam, micro beam and top of GFRG panels (50 mm thick) with M-25 cement concrete mix using coarse aggregate of size less than 20 mm including laying of 10 gauge 100mmx100mm size weld mesh with 25 mm effective cover from the panel top.

Supplying and fixing 10 Gauge weld mesh of size 100mm x100 mm for floor/roof slab concrete screed over the micro beams as reinforcement. The weld mesh shall be fixed as per drawing.

4. Waterproofing Applications & Sealing of Joints

- i. Application of ZMB 60/equivalent solution (100 Kg ZMB 60/equivalent, 1 litre ZMB Nano Thinner, 20 litre water & 1 Litre Zycoprime/equivalent = 122 litre/kg) over already applied coat of Zycosil/equivalent & Zycoprime/ equivalent solution on the top of all the RCC plinth beams by brush/spray coat before erection of GFRG over RCC plinth beams in GF. In the case of upper floors 150 mm wide on floor slab for all the external walls, bath/toilet/ wet areas (3 hrs drying time) before erection of wall panel on upper floors including erection of parapet wall.
- ii. After erection of GFRG wall panels, seal all GFRG wall joints with paper tape temporarily. Water proofing treatment of vertical joints with

Zycosil/equivalent water proofing Solution (1 litre of Zycosil/equivalent & 20 litres of water stirred first & 2 litres of Zycoprime/equivalent added and stirred (total 23 litres)) with 50 ml syringe till the gap and in filled concrete is completely saturated. After removing the paper seal, seal off the vertical joints with water proofing material “Grout RW/equivalent”.

- iii. Filling of joints between RCC plinth beam / floor slab and wall panel of external walls, toilet / bath room / wet areas walls on all floor and parapet wall over roof slab, stair case head room at the time of erection of GFRG panels with Grout RW/equivalent sealant compound after the erection of panel before the infill of concrete in panel cavities and fine finish. This applies for all horizontal and vertical joints between GFRG wall and slab panels.
- iv. Water proofing treatment of Vertical joints (of external side and internal side) between door frame, window & ventilator frames (on all four sides) of outer wall over the Zycosil/equivalent & Zycoprime/equivalent solution already applied (before the installation of door / window / ventilator frames in position) and fine finish with Grout RW/equivalent.
- v. Water proofing treatment of RCC sunshade with Zycosil/ equivalent water proofing Solution (1 litre of Zycosil/ equivalent & 20 litres of water stirred first & 2 litres of Zycoprime/equivalent added and stirred (total 23 litres)) till it meets the saturation level and testing as per RILEM or by water drops test in which water drops do not absorb but drops remain or rolls.
- vi. In-filling / sealing of joint between RCC lintel cum sunshade and wall (on external side) in all floors by pushing in Grout RW/equivalent in paste form and coving 20 mm x 20 mm after applying a coat of Zycosil/equivalent & zycoprime/equivalent solution before cement plastering of top, bottom and sides of RCC sunshade.

All relevant Indian Standards/ requirement of NBC shall be conformed.

2.6.3 Structural Stay In Place Galvanized Steel formwork system (M/s Coffer Construction Technology Pvt. Ltd)

Brief Discription

The form work system comprises of two filtering grids made of rib mesh reinforced by ‘C’ channel vertical stiffeners.

The grids are connected by rebar which act as horizontal stiffeners and connect or which act as a shear link. The grids on both faces act as sacrificial formwork in which concrete is poured in-situ. The vertical steel channels and horizontal steel bars act as steel reinforcement for load bearing wall. The connectors help to fold the formwork for easy transportation.

After the erection of formwork panels in alignment, corners, edges of doors and windows frame are closed with rebar positioning & concrete of required grade is poured in the panels. The concreting may be done with a pump,

bucket or with a shovel loader. The inside and outside walls are finished with cement plaster of suitable grade.



The panels are prefabricated according to a structural plan (based on client's architectural plans) designed by structural engineers.

Product assembly Components in Structural Stay-in-Place Formwork Panel:

The various parts of Structural Stay-in-Place Formwork panel are explained briefly below:

C-Chanel

These are vertical stiffeners, work as vertical steel in Reinforced Concrete wall

It is made up of 0.6mm thick galvanized sheet. The 180GSM to 275GSM zinc coating is used based on geological location to prevent rusting of steel.

Area of profile is 60.6 mm^2 (i.e. $> 8 \text{ mm}$ dia bar)

Placed at every 200 mm distance along the width

Rebar

Rebar's are horizontal stiffeners at every 200mm or 100mm centre to centre

It is 5 mm dia MS bars and work as distribution bar.

Made up of Fe 415 Grade steel

Connector

Connects C profile & Rebar.

It is made up of 1.6 thick Cold Rolled Cold Annealed (CRCA) plates of 120 gm/m^2 zinc coated sheet to prevent rusting

Works as shear link to connect steel on both face of form work.

Also helps to avoid bulging of formwork during concrete pouring.

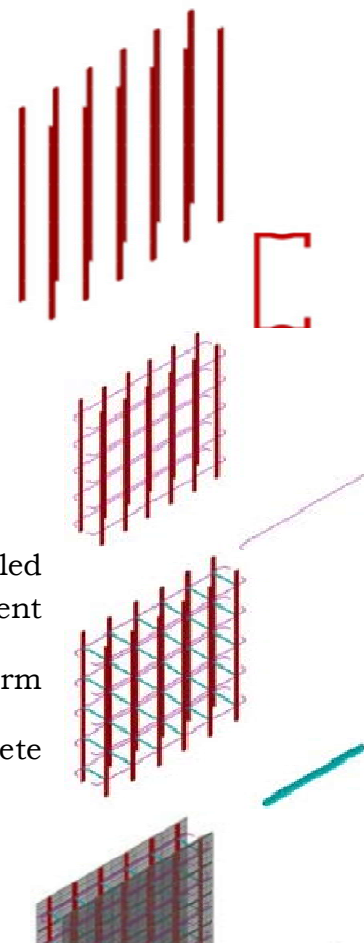

Part – 4: Rib Mesh

Rib meshes are filtering grids.

They are made up of 0.42mm thick high galvanized sheet with 180 GSM to 275 GSM zinc coating used as per geologic allocation to prevent rusting of steel. It works as reinforcement to plaster to prevent crack generated due to contraction and expansion. Also provide good bonding to plaster

Size and Types of Panels

Panels are normally produced in sizes as given below (See Fig. 2): Width (W): 300mm, 500mm, 700mm, 900mm & 1100mm Height (H): 500mm to 5000mm in multiples of 100 mm. Thickness (T): 100mm, 140mm, 160mm, 200mm & 250mm. However, customized sizes also be made available on demand.

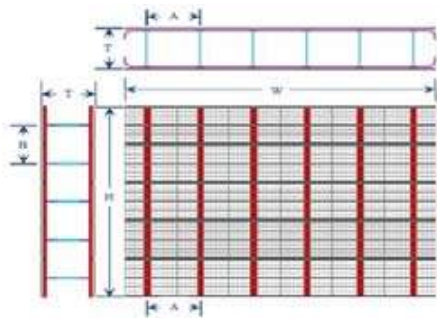

Panel Type	T mm	A mm	B mm	W mm	H mm
C10	100	200	100, 200	300,	Min.
C14	140	200	100, 200	500,	500
C16	160	200	100, 200	700,	then
C20	200	200	100, 200	900,	in multiples
C25	250	200	100, 200	1100	of 100

Fig.2

Types of panels are given below:

- i. Standardsinglepanels–
These panels shall be used for slab shuttering but may also be used as shuttering option for RCC wall having thickness of more than 350mm. (Fig. 3)
- ii. Doublepanels–
Double panels shall have inbuilt steel and not require extra reinforcement. In double panels, the grids shall be connected by articulated rebar loops and connectors that fold.

These panels are of two types:

- a. Standard double panels shall be of fixed size and need to be cut on site for openings etc.
- b. Customized double panels from the factory shall have required cutting for openings as per drawing and there is no need for cutting on site.
- c. These panels create a monolithic structure as it allows pouring of walls and slab together. These panels shall be used for load bearing walls, retaining walls and shear walls. (Fig. 4)
- iii. Insulated Double panel– These panels shall have an integrated insulation on the exterior side. The insulated material shall be of polystyrene or polyurethane of required thickness as per design. (Fig. 5)
- iv. Fiber Cement Double panel– These panels shall have its interior face as fibre cement board which has smooth surface and avoid plastering of walls. (Fig.6). These panels may be used for water retaining structures.

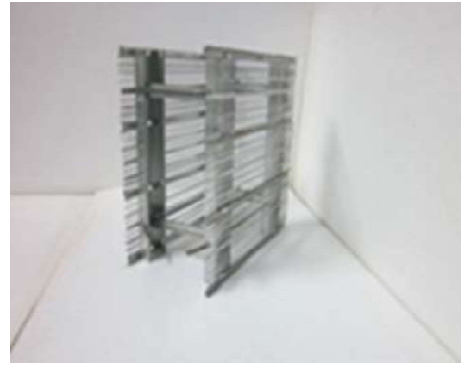

Fig.3 Standard Single Panel Fig.4 Standard Double Pane



Fig.5 Insulated Panel



Fig.6 Fiber Cement Panel

Foundation

Strip Footing or normal column and beam structure up to Plinth level based on soil condition.

In case of Strip footing, Coffor panels will start from foundation and on the top of strip concrete raft which increase speed to come out from the ground.

Installation of Panel:

Layout and Blocking

The alignment shall be traced with chalk on the two sides. Boards/batten shall be nailed on the ground to indicate the positioning of one face of the panels.

Positioning the Panel

- The Structural formwork panels shall be fitted over projecting vertical reinforcing rods. Each panel shall be held vertically with wood pieces (boards/battens) or metal pieces (L-sections/tubes). The minimum length of these bracing elements shall not be less than 1.80m. The panels shall preferably be positioned beginning from the angles and from the doors. Whenever length of the wall does not correspond to a multiple of width of the panels, the last panel shall be cut with a rotary saw to adjust to length

of the wall. The horizontal battens shall be installed on a single side. The verticality shall be checked using a plumb line or level.

- Shuttering of Slab: after completion of Coffor panel installation of the wall, slab shuttering will start either with use of Coffor single panels or normal conventional shuttering for RCC or any other slab.
- Plumbing and Electrification: After installation of slab shuttering, electrical and plumbing conduits can be placed in between panels. For installing the electrical box, panels can be cut with small grinder machine.
- Panel alignment & slab steel needs to be checked & ensured prior to concreting.
- Concrete Pouring: The placing of concrete of specified grade is done in wall and slab in one go with either with Boom placer, stationary pump or manually. As all concreting is done in one go, a monolithic reinforced concrete structure is created.

Structural Requirements of the Construction

Design analysis of the Structural formwork walls, panels, floor slabs etc. shall be done using Staad Pro Software or equivalent. The Optimal result is obtained when walls shall be designed as braced construction elements whose horizontal loads are supported by other bracing elements belonging to the same construction e.g. shear walls. The panels with concrete shall act as “lightly reinforced RCC walls” as per clause 32 of IS 456:2000 and as “prefabricated concrete load bearing walls” as per IS 15916:2010 & IS 15917:2010 & IS 15971:2010.

Structural design and analysis of the formwork shall be based on relevant Indian and International standards. The panel construction assembly shall be used for free standing walls when designed and anchored as cantilever walls. Panels shall be reinforced and tied at vertical joints to maintain alignment. Additional reinforcement and cement plaster shall be provided as per the design requirement. Foundation shall be specifically designed in accordance with provisions given in IS 1904:2005. All relevant Indian Standards/ requirement of NBC shall be conformed.

2.6.4 Stay-in-Place Formwork System PVC Form for Shear Walls (M/s Joseph Jebastin (Novel Assembler Private Limited))

Brief Description

Stay in place PVC form wall System consists of rigid poly-vinyl chloride (PVC) based polymer components that serve as a permanent stay-in-place durable finished form-work for concrete walls. The extruded components slide and interlock together to create continuous formwork with the two faces of the wall connected together by continuous web members forming hollow rectangular components. The web members are punched with oval-shaped cores to allow easy flow of the poured concrete between the components. The hollow Wall

components are erected and filled with concrete, in situ, to provide a monolithic concrete wall with enhanced curing capacity due to water entrapment, as the polymer encasement does not allow the concrete to dry prematurely with only the top surface of the wall being exposed to potential drying. The polymer encasement provides crack control vertically and horizontally for the concrete, and provides vertical tension reinforcement thus increasing the structural strength of the wall. Steel dowels are necessary to anchor the wall to the concrete foundation.

Size of Panels

Size: Wall Panels have been developed in various cross-sectional sizes as per project requirement. The common sizes are 64mm, 126mm, 166mm & 206mm. However available wall types are as follow:

Wall components	Wall Thickness		
	Overall (Nominal)	Concrete Core	Insulation ¹
N64	64 mm	60 mm	0
N126	126 mm	120 mm	0

- N64 walls are erected individually and not preassembled, except for headers and sills.
- Pre-assembled walls sections are used for walls over 4300 mm (14') high
- The height of walls made with the Formwork vary according to the requirement.
- N126 walls less than 4300 mm (14') high are erected individually except for walls of unique projects and for headers and sills.

Panel Components

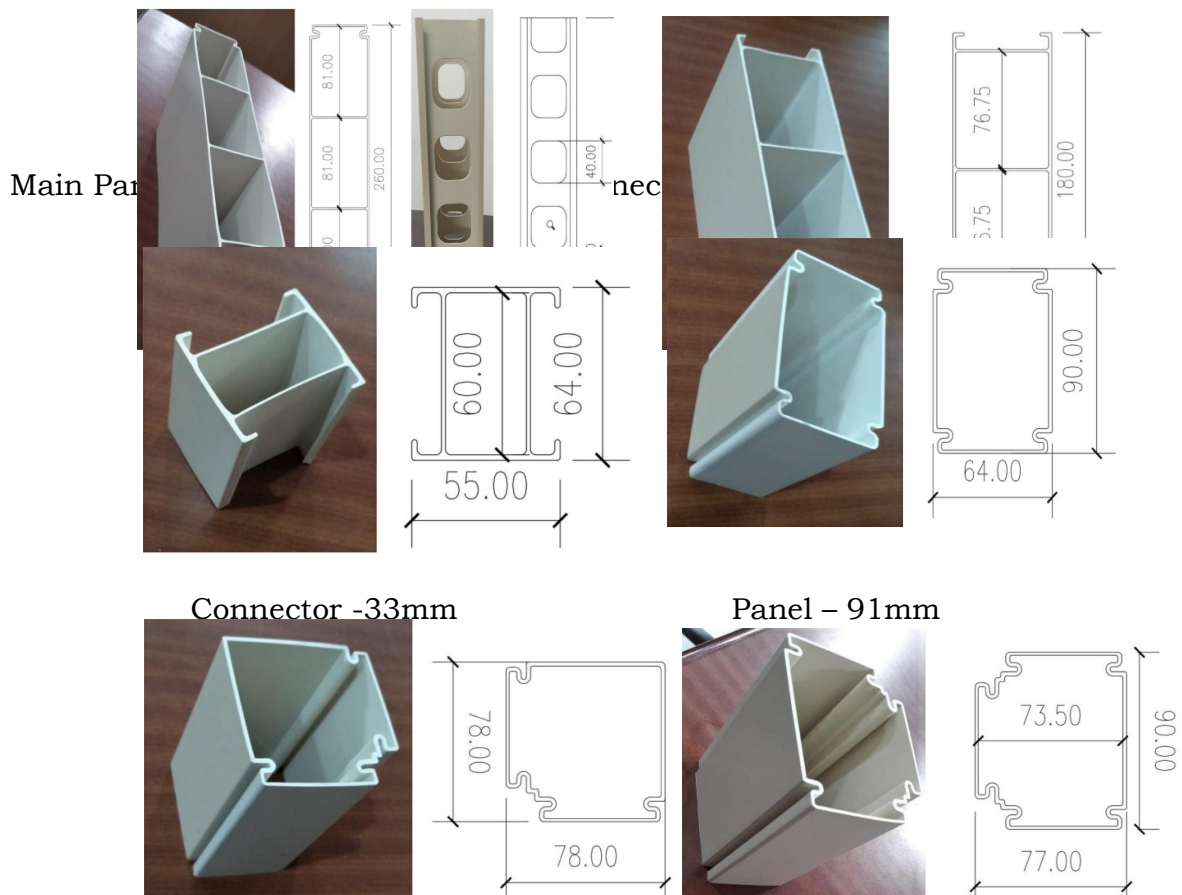

Corner Panel

3-WAY (T-CONNECTOR)

Jointer C

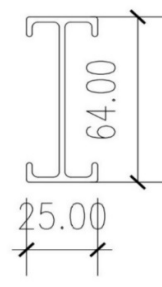
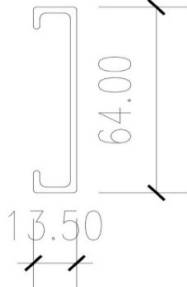
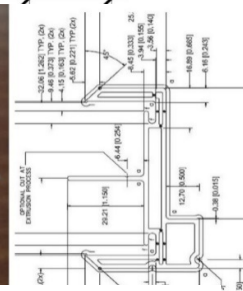
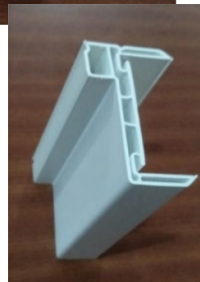
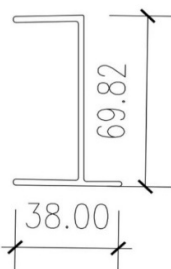
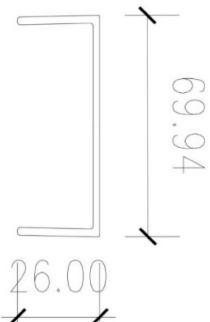
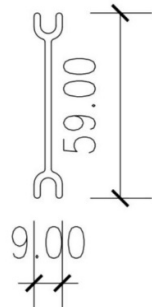

Starter

Design Consideration

General

The walls shall be designed to accommodate a wide range of axial, wind and seismic load conditions, using the equations developed for conventional and slender concrete walls. However, one of the unique properties of Novel walls is the ability of the permanent polymer formwork to provide concrete confinement and reinforce the concrete in tension. There are two main structural elements used in the wall, namely panel sections and box connectors. The panels come as three-cell sections 250 mm wide, while the box connectors are one-cell sections 64 mm wide. The webs of these elements have oval cores which allow lateral flow of the poured concrete between the adjacent cells and provide a mechanical transfer of forces between the concrete and the polymer thus creating a composite action.

Floor/Slab

In-situ RCC slab as per IS:456:2000 shall be provided.

Structural Aspects

The buildings constructed with the system walls shall be designed as reinforced concrete structure since the parameters required for their design are the same as needed for traditional reinforced concrete. The building shall be designed in accordance with IS 456:2000, as applicable.

The system shall be designed to provide the required performance against the loads to be taken into account in accordance with IS 875 (Parts 1-5):1987 and the data given by manufacturer for various panels. It shall also provide the required bearing resistance for earthquake and wind forces as per IS 875 (Part 3):2015 and IS 1893 (Part 1):216, wherever applicable.

Foundation shall be specifically designed in accordance with provision given in IS 1904:2005. Both single and double panels should have starter bars from either foundation or ground floor slab.

The structural design calculations should clearly demonstrate structural integrity and stability including connection details. In addition, any other requirement regarding safety against earthquake need to be ensured by the designer as per prevailing codal requirements. All relevant Indian Standards/ requirement of NBC shall be conformed.

2.6.5 Insulating Concrete Forms (ICF) System (M/s Reliable Insupack Building Solutions)

Insulating concrete Forms (ICF) System comprises of a panel of two walls of *Expandable Polystyrene* (EPS) separated by a nominal distance of 150mm by hard plastic ties. These are assembled on site to hold reinforced concrete. The forms are open ended hollow polystyrene blocks which fit tightly together to form a shuttering system. Concrete poured into the hollow space to form a continuous wall. When cured, this wall supports the structural loads from floors and roofs, and the shuttering provides thermal insulation. Reinforcing steel shall be as required as per the design parameters. Upper and lower surfaces of the polystyrene panels are castellated and the vertical mating surfaces are tongue-and-groove to form a tight fit when joined together. The rigid formwork does not require supporting falsework. Form locks are used for end stops. The outer surfaces are grooved vertically at 50 mm centres to aid cutting and trimming. Plan view of ICF is shown in Fig. 1.

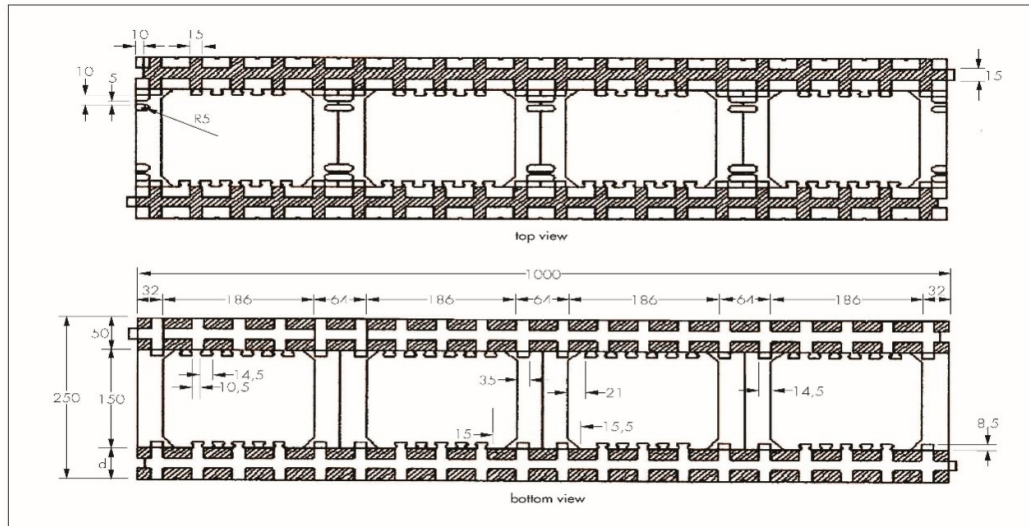

Fig. 1
Types of Forms

Standard Forms – These form bulk of the forms and have 50mm EPS panels on both sides with hard plastic ties holding the panels. Dimensions of these forms are 1000 x 250 x 250mm. (See Fig. 2)

Lintel Forms -In combination with Half Height forms, these form the top layer of all wall gaps and hold the concrete thus preventing thermal leaks. Dimensions of these forms are 1000 x 125 x 250mm. (See Fig. 3)

Half Height Forms –Together with the lintel, these form the top layer of all gaps in the wall and hold the required steel reinforcement. Dimensions of these forms are 1000 x 150 x 250mm. (See Fig. 4)

Floor Edge Forms – These form the top most layer, where the wall ends and floor begins. This envelopes the floor slab and thus prevents thermal bridging. Dimensions of these forms are 1000 x 375/125 x 250mm. (See Fig. 5)

Corner Forms –These constitute 90° corner of the building.The two sides are 50mm EPS panels held together with 8 hard ties. Dimensions of these forms are 750/500 x 250 x 250mm. (See Fig. 6)

End Forms –These create wall ending by fitting in inside the Standard or Corner form and provide a smooth and thermal bridge ending to the wall. Dimensions of these forms are 150 x 125 x 50mm. (See Fig. 7)

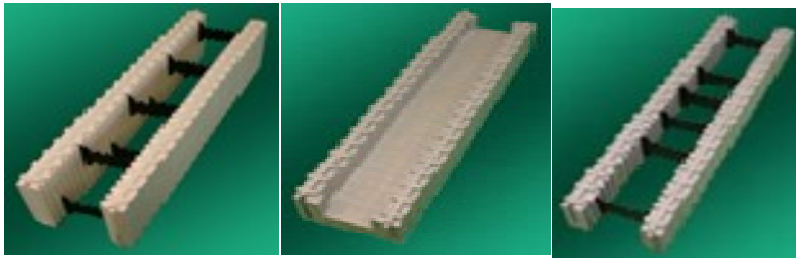

Fig. 2 Standard

Fig. 3 Lintel

Fig. 4 Half Height

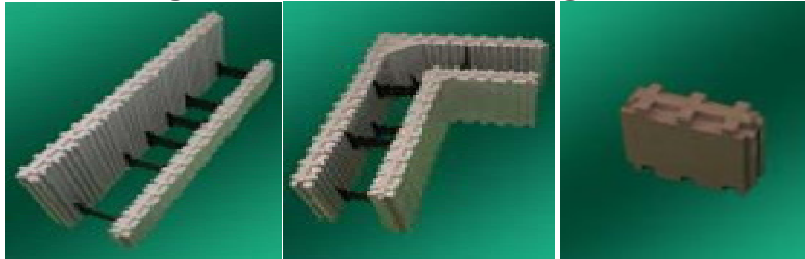

Fig. 5 Floor Edge

Fig. 6 Corner

Fig. 7 End

Typical construction

Construction process

The construction of most Insulating Concrete Forms (ICF) & Monolithic Insulated Concrete Systems (MICS) buildings is fundamentally a process of stacking lightweight blocks together in a similar manner to building bricks, laying reinforcement where necessary and pouring concrete into the voids of the block work.

Footings

The footings for Insulating Concrete Forms (ICF) & Monolithic Insulated Concrete Systems (MICS) buildings shall be reinforced concrete rafts or strips that are flat and even enough to enable stacking of the form blocks, with reinforcement starter bars set ready to connect with the concrete when poured into the formwork.

Load bearing walls

Any Insulated Concrete System/Forms wall can be designed to be load bearing.

Joints and connections

Joints and connections with other building elements shall be kept to a minimum, especially when the flooring or roofing elements are also made from Insulated Concrete System/Forms.

Fixings

The foam block work or form work forms a poor basis for any fixings. Light loads are generally carried by the lining or facing materials, such as plaster board, and heavier loads can be carried by supporting points drilled in to the concrete that forms the inner material of the Insulated Concrete System/Forms.

Openings

Major openings for doors, windows, etc., shall be set out in the form work as it is relatively difficult to make changes later, owing to the fundamentally monolithic nature of the structural elements. Once openings have been made, they can accommodate window and door frames of any type. A typical kind of fixing uses timber blocks set in to the ends of the form blocks around the opening. Electrical conduit and plumbing is generally run in chasing in the depth of the form blocks.

Finishes

Finishes are dependent on the materials used to face the Insulated Concrete System/Forms units. Typically, the main finish is a render or render-equivalent covering or paint. Any additional cladding can be added to the Insulating Concrete Forms (ICF) & Monolithic Insulated Concrete Systems (MICS) walls subject to making appropriate supports for it, although many sheet finishes, such as plaster board, can be glued directly to the surface of the formwork. External renders require a base or skim coat embedded with fiber glass mesh, followed by a second coat and then a texture coating, finally finished with an 'armor coat'.

RAW MATERIALS

- Expanded Polystyrene (EPS): Self-extinguishing type EPS shall conform to IS 4671: 1984 having density not less than 25 kg/m³ and valid Restriction of Hazardous Substance (ROHS) test certification.
- Polyurethane (PU) Foam Adhesive: Shall have Skin Formation of 8 min, Density 25 kg/m³, Sound insulation 58 dB, Insulation factor 35 mW/mK, Shrinkage < 2%, Fire rating B3, Insulation factor 35 mW/m.K and Water absorption of 1 % volume
- Plasticizer: Slump retaining super plasticizer for self-compacting plastic concrete (CEMWET SP-3000) shall conform to IS 9103:1999
- Hard Plastic Tie: Shall be made with High density polyethylene ensuring stability
- Cast-in-place concrete: The ingredients, grade of concrete & slump for walls, floors and roofs shall be used as per IS 456:2000.

Structural Aspects

The Insulating Concrete Forms (ICF) & Monolithic Insulated Concrete Systems (MICS) may be designed using the appropriate design software. The buildings constructed with EPS shall be designed as reinforced concrete structure since the parameters required for their design are the same as needed for traditional reinforced concrete. In the calculation model, the building shall be designed in accordance with IS 456:2000, as applicable, as structure composed of load bearing walls with a box-like structure.

The system shall be designed to provide the required performance against the loads to be taken into account in accordance with IS 875 (Parts 1,2,4&5):1987. It shall also provide the required bearing resistance for earthquake and wind forces as per IS 875 (Part 3):2015 and IS 1893(Part1):2016, wherever applicable. All relevant Indian Standards/ requirement of NBC shall be conformed.

**2.6.6 Building PVC wall material
(M/s Kalzen Realty Pvt. Ltd)**

Brief Description

Stay-in-place formwork consisting of hollow□type rib- reinforced Poly-vinyl chloride (PVC) material comprising of two PVC panel facings with internal PVC ribs, are used as permanent formwork for concrete walls. The web members are punched with cores to allow easy flow of the poured concrete between the components. After putting vertical & horizontal reinforcement as per the design, the hollow Wall components are filled with concrete, in situ, to provide a monolithic concrete wall.

Standard Panels

The standard size of available panels is as follows;

Height	Standard panels: 3 meters or 3.3 meters heights All panels can be ordered to custom height Minimum 0.5m; Maximum 6m
Panel width	Standard wall panels: 400mm Half wall panels: 200mm Quarter panels: 100mm
Thicknesses of Profile	110, 150 and 200 mm
PVC thickness	2.5 mm
PVC density	1,300 kg/m ³
Concrete volume	110mm profile: 0.10 cum per sqm 150mm profile: 0.14 cum per sqm 200mm profile: 0.18 cum per sqm
Weight	110mm profile: 18.1 kgs per sqm 150mm profile: 21.6 kgs per sqm 200mm profile: 23 kgs per sqm

The product shall not be affected by exposure to sunlight either in storage or as part of finished product.

Walling System

The wall shall be erected by placing the panels side by side or sliding the new panel down from top and held by using the clipping mechanism. The panel shall have double-hole system ensuring the position of the horizontal and vertical steel reinforcing bars.

The horizontal bars shall be placed along with the laying of panel and vertical bars shall be placed by dropping from top to improve the accuracy and structure of the wall, and minimize variations in the

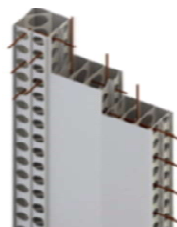

concrete thickness surrounding the reinforcing bars. Once the wall is erected, the plumbing and electrical conducting is done as per the design. After this, concrete of required Gauge as per structural design shall be poured into the cavities. Once filled, the system acts as structural element. The external surface shall have specified finish.

Floor/Slab

In-situ RCC slab as per IS:456:2000 shall be provided.

Structural Aspects

The buildings constructed with the system shall be designed as reinforced concrete structure since the parameters required for their design are the same as needed for traditional reinforced concrete. The building shall be designed in accordance with IS 456:2000, as applicable.

The system shall be designed to provide the required performance against the loads to be taken into account in accordance with IS 875 (Parts 1-5):1987 and the data given by manufacturer for various panels. It shall also provide the required bearing resistance for wind forces & earthquake as per IS 875 (Part 3):2015 and IS 1893 (Part 1):2016, wherever applicable.

Foundation shall be specifically designed in accordance with provision given in IS 1904:2005. Both single and double panels shall have starter bars from either foundation or ground floor slab.

The structural design calculations should clearly demonstrate structural integrity and stability including connection details. In addition, any other requirements including safety against earthquake, cyclone shall be ensured by the designer as per prevailing codal requirements. All relevant Indian Standards/ requirement of NBC shall be conformed.

2.6.7 Fast Bloc Insulated Concrete Form (ICF) (M/s Fast Bloc Building System)

Brief Description

The Fast Bloc Building System (Fast Bloc) is stay-in-place, formwork for reinforced concrete, post and beam construction, thus creating skeleton with required strength within the wall. In the System, Expanded Polystyrene (EPS) blocks are stay in place forms which provide insulation and sound barrier. Concrete and rebar shall be installed along the wall as per design requirement.

Standard Panels

Standard Fast Bloc has two different sizes as below;

1. 15.10 cm (6 inches) x 30.50 cm (12 inches) x 121.00 cm (48 inches),
2. 20.32 cm (8 inches) x 30.50 cm (12 inches) x 121.00cm (48 inches)

These two sizes can be assembled to cater the needs of any project. The spacing of the cells allows for walls to be reinforced based on the needs of the project, location, number of stories, and other parameters based on structural design. As per the requirement, Lintel blocks shall be used.

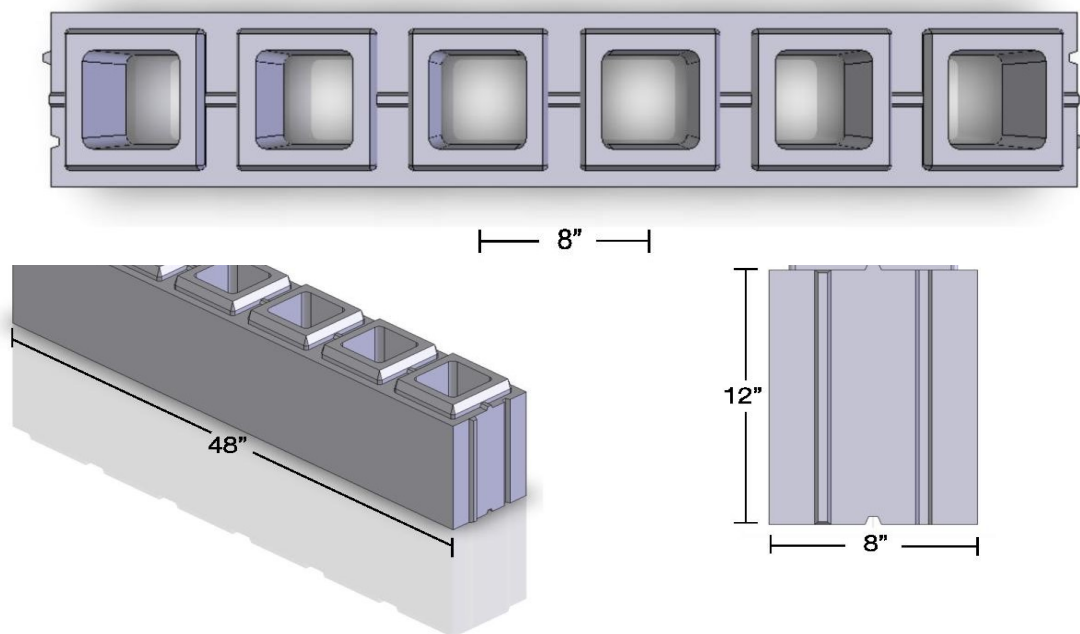

Fig. FastBloc®

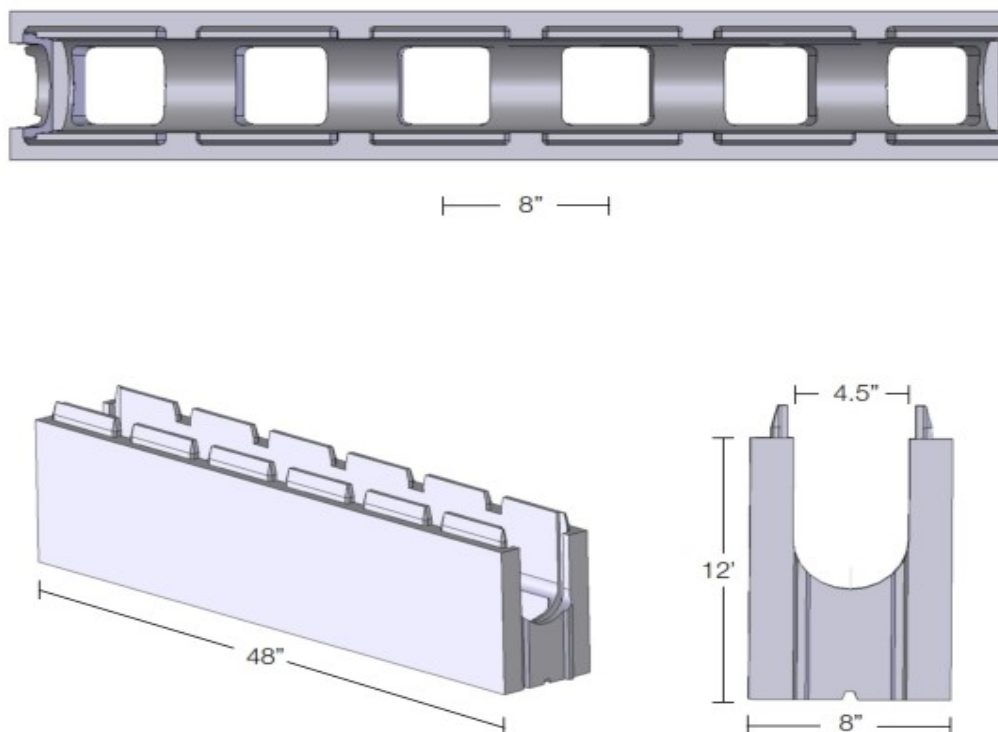

Fig. Fast Bloc® for Lintel

Walling System

To construct a Fast Bloc wall, parts shall be assembled similar to "Lego" blocks, by placing the pieces and form walls, known as "reinforced post and beam construction."

The plugs need to be placed in the cells that do not have vertical rebar reinforcement (per structural calculations), so they are not filled with concrete. The end caps provide an enclosure for the lintel at the end of walls. The vertical cells that are not filled with concrete can be used for electrical and / or plumbing.

Before pouring concrete, end plugs shall also be placed in the lintel beams at the end of walls to seal the blocks horizontally.

Utility Installation

The utilities shall be inserted before filling the walls with concrete. The utilities need to be properly placed in the foundation prior to installation of Fast Bloc in order to align with the center of the wall and an open Fast Bloc cell. It is important that the utilities do not interfere with the cells used for concrete and rebar, otherwise the utilities could cause a discontinuity in the concrete and steel and create a cold joint. The large-diameter pipes shall be put outside of the wall. The electrical boxes or load centers are to be placed prior to casting of the walls so they are drowned in concrete. Holes can be cut into Fast Bloc® walls where utility outlets are required.

Floor/Slab

In-situ RCC slab as per IS:456:2000 shall be provided. Speed floor as per design may also be provided.

Structural Aspects

The buildings constructed with the system walls shall be designed as reinforced concrete structure since the parameters required for their design are the same as needed for traditional reinforced concrete. The building shall be designed in accordance with IS 456:2000, as applicable.

Foundation shall be specifically designed in accordance with provision given in IS 1904:2005. When performing the assembly of the foundation, depending on the type, vertical reinforcement rods (rebar) shall necessarily be inserted.

The structural design calculations should clearly demonstrate structural integrity and stability including connection details. In addition, any other requirement regarding safety against earthquake, cyclone shall be ensured by the designer as per prevailing codal requirements. All relevant Indian Standards/ requirement of NBC shall be conformed.

2.6.8 Plaswall Panel System (M/s FTS Buildtech Pvt. Ltd)

Plaswall Panel System is a lost in place formwork, where two fiber cement boards (FCB) of 6mm thickness each and HIMI spacers (High Impact Molded Inserts) bonded between two sheets of FCB(in-situ) are erected to produce straight-to-finish panels. A monolithic structure is then created by filling the entire structure with M20 or high ergrade of concrete as per the design. Additional load capacity can be obtained by providing extra reinforcing bars and/or by increasing grade of the concrete.

An Isometric View of the Plaswall is shown in Fig. 1 below:

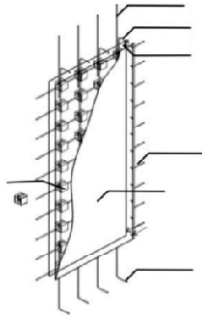

STARTER BARS FOR
NEXTFLOOR SHEAR
CONNECTOR BAR
EXT.
FROM VERT.REINF.
SHEAR
CONNECTOR BAR
EXT. FROM
VERT.REINF.

HOTIZONTALREINF.BAR

SPACER
FCB BOARD

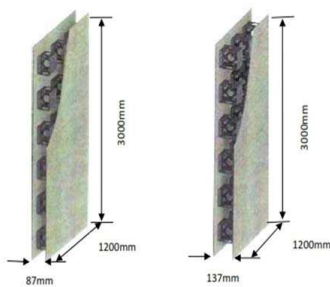

STARTER BARS FROM
FOUNDATION

3.1 SIZE OF PANELS

3.2 Panels are normally produced in sizes and dimensions as below:

3.3 Length: 2400mm/3000 mm

3.4 Width: 1200 mm

3.5 Thickness: 87 mm, 112 mm, 137 mm, 162 mm & 230 mm including two fiber cement boards of 6mm thickness each and infill of concrete of 75mm, 100mm, 125mm, 150mm and 218mm. The dimensional sketches are shown in Fig.

Raw Materials

- Fiber cement board shall be 100% as best osfree and conform to TypeA, Category 3 min. as stipulated in IS14862:2000.
- RecycledplasticspacerismadeofHighImpactMoldedInsertsshallconformtothespecificationsoftheManufacturer.
- PU Adhesive Glue shall conform to the specifications of the manufacturer.
- Putty shall conform to IS 419:1967.
- Cement, sand, aggregate and reinforcement steel shall be as per the relevant Indian Standards.

Construction, Installation and Jointing Procedure of Plaswall Foundation

The foundation type as raft, strip, isolated footing shall be decided based on bearing capacity of the soil, site condition, etc. However, the provision for starter bars for walls shall be ensured in all foundation scenarios. Typical sketch for starter bars from foundation are given below (Fig.7).

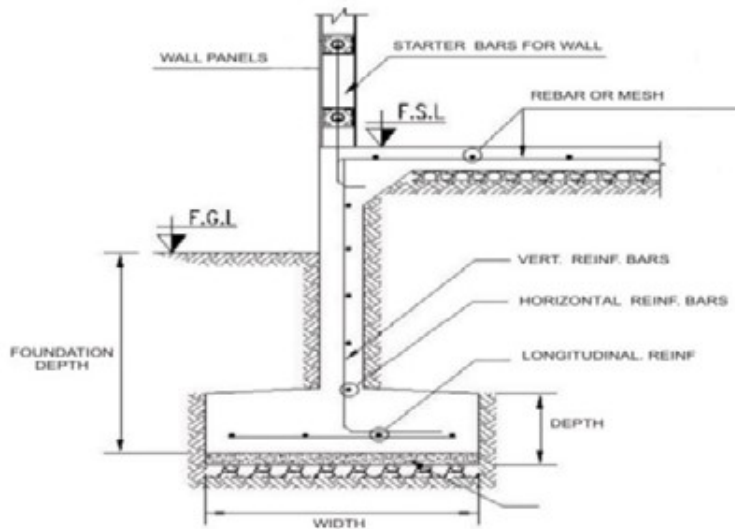

Fig. 7 Typical Strip footing

Panel Installation

Installation

The panel shall be lifted slightly and then placed along the bottom angles. The panel shall be plumbed at edge and face sides with provision of shims, if needed.

- The panel shall be screwed both sides at bottom at 250 mm center to center, while glue is applied & tacky. If glue is not available, spacing shall be kept at 200mm center to center.
- Support the temporarily angle installed on other side of panel to hold it in position for concreting (Fig. 8)
- Corner connection details shall be followed as shown in Fig. 9.

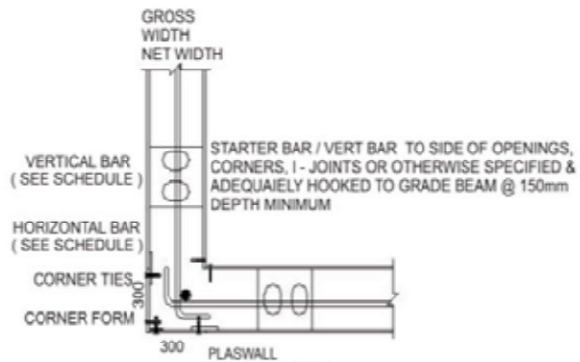

Fig. 8 Diagonal bracing Fig. 9 Corner connection

T-Section

- After installing the primary walls, mark the place where corner will be constructed.
- The joiner stud shall be placed and marked by pencil to have a vertical line reference.
- The joiner stud shall be moved up by 60mm from slab to bottom of joiner stud. The stud hole shall be marked by pencil.
- The marked slots shall be cut by 100mm angle grinder with dry type diamond blade.
- Reinforced dowels shall be prepared, inserted & tied just after screwing the joiner stud corner connection.(Fig.9)
- In case, the holes intersect with panel stud of the primary wall, the portion of primary stud shall be cut to accommodate the marked holes for T-connection. One 12mm vertical bar shall be provided as replacement.
- In case of cross-connection, horizontal bars shall be provided.

Nib End Wall Detail

- For nib, end cap shall be provided.
- Glue shall be applied on end cap stud which shall be inserted to correct position and screwed. (Fig. 10)

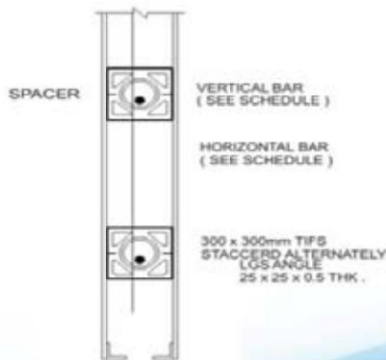

Fig. 10 Nib End Wall Detail

Fig. 11 Door & Window Jambs

Door & Window Jambs Installation

- Light gauge door & window jambs shall be provided for the panels Door